



The information in this documents is subject to change without notice and should not be construed as a commitment by ABB. ABB assumes no responsibility for any errors that may appear in this documents.

Except as may be expressly stated anywhere in this document, nothing herein shall be construed as any kind of guarantee or warranty by ABB for losses,damages to persons or property, fitness for a specific purpose or the like.

In no event shall ABB be liable for incidental or consequential damages arising from use of this document.

This document and parts thereof must not be reproduced or copied without ABB's written permission, and contents thereof must not be imparted to a third party nor be used for and unauthorized purpose.

Additional copies of this documents may be obtained from ABB at its then current charge.

© Copyright ABB All Right Reserved.

ABB China Ltd.Corp
CNAUS Robotics
SHANGHAI CHINA

We reserve all rights in this document and in the information contained therein. Reproduction, use or disclosure to third parties without express authority is strictly forbidden. Copyright ABB

Responsible Department: RATA - RD Design by: Yan Zhang		IRT 710			ABB COPYRIGHT	Status: Approved	=		
Prepare by,Date:CNVAZHA48,20240915	Approve by,Date:CNFALEG,20240920	Replacement of	Replaced by			Document no. 3HKA00000191004	+	Rev.Ind	Page
								Total Page	33



Description : IRT 710
 Drawing number : 3HKA00000191004
 Drawing version : 002
 Date : 9/20/2024

Customer :
 Year of construction :

Drawn by : Yan ZHANG
 Number of pages : 33

We reserve all rights in this document and in the information contained therein. Reproduction, use or disclosure to third parties without express authority is strictly forbidden. Copyright ABB

Responsible Department: RATY - RD	Design by: Yan Zhang
Prepare by,Date:CNVAZHA48,20240915	Approve by,Date:CNFALEG,20240920

IRT 710	
Replacement of	Replaced by



TITLE PAGE

Status: **Approved**
 Document no. **3HKA00000191004**

Rev.Ind	Page
	2
Total Page 33	

Table of contents

Column X: An automatically generated page was edited

F06_001

Page	Page description	supplementary page field	Date	Edited by	X
1	ABB COPYRIGHT		4/20/2022	CNLAZHA4	X
2	TITLE PAGE		4/20/2022	CNLAZHA4	X
3	Table of contents : 1 - 33		9/11/2024	CNYAZHA48	
4	BLOCK DIAGRAM IRB SMB CONNECTION for IRB4600, 6620,6650s,6660,6700,660,760,7600		9/5/2024	CNYAZHA48	
5	BLOCK DIAGRAM CONNECTION for IRB6620,6650S,6660, 6700,7600(spot welding)		9/11/2024	CNYAZHA48	
6	BLOCK DIAGRAM IRT SMB BOX CONNECTION IRB4400 IRB460		8/20/2024	CNYAZHA48	
7	BLOCK DIAGRAM IRT SMB BOX CONNECTION TRANSFER CARRIAGE		9/5/2024	CNYAZHA48	
8	MOTOR IRT, IRB4600/660/ 6620/6650S/6660/6700/760/7600		9/11/2024	CNYAZHA48	
9	MOTOR IRT, IRB460/4400		9/11/2024	CNYAZHA48	
10	MOTOR IRT, OPTION SERVO GUN		9/11/2024	CNYAZHA48	
11	MOTOR IRT, TRANSFER CARRIAGE STATIC CABLE		9/11/2024	CNYAZHA48	
12	MOTOR IRT, TRANSFER CARRIAGE SMB 1(6 Axes)		9/11/2024	CNYAZHA48	
13	MOTOR IRT, TRANSFER CARRIAGE SMB 2(1 Axes)		9/11/2024	CNYAZHA48	
14	MOTOR IRT, TRANSFER CARRIAGE MOTOR		9/11/2024	CNYAZHA48	
15	MOTOR RESOLVER, IRB46x0/6xx0/760/7600		9/11/2024	CNYAZHA48	
16	MOTOR RESOLVER STATIC CABLE		9/11/2024	CNYAZHA48	
17	MOTOR RESOLVER, IRB4400, IRB460		9/11/2024	CNYAZHA48	
18	MOTOR RESOLVER, OPTION SERVO GUN		9/11/2024	CNYAZHA48	
19	MOTOR RESOLVER CONNECTION		9/11/2024	CNYAZHA48	
20	MOTOR RESOLVER, TRANSFER CARRIAGE STATIC CABLE		9/11/2024	CNYAZHA48	
21	MOTOR RESOLVER, TRANSFER CARRIAGE SMB 1(6Axes)		9/11/2024	CNYAZHA48	
22	MOTOR RESOLVER, TRANSFER CARRIAGE SMB 2(1Axes)		9/11/2024	CNYAZHA48	
23	MOTOR RESOLVER, TRANSFER CARRIAGE MOTOR		9/11/2024	CNYAZHA48	
24	MOTOR CABLE, IRB4400		9/11/2024	CNYAZHA48	
25	MOTOR CABLE, IRB4400		9/11/2024	CNYAZHA48	
26	MOTOR CABLE, IRB460/760/4400/4600/6xx0/7600		9/11/2024	CNYAZHA48	
27	RESOLVER CABLE, IRB460/760/4600/6xx0/7600		9/11/2024	CNYAZHA48	
28	OPTION CUSTOMER POWER/SIGNAL, IRB4400		9/11/2024	CNYAZHA48	
29	OPTION CUSTOMER POWER/SIGNAL, IRB460/760/4600/6xx0/7600		9/11/2024	CNYAZHA48	
30	OPTION CUSTOMER POWER/SIGNAL PARALLEL, IRB460/760/4600/6xx0/7600		9/11/2024	CNYAZHA48	
31	OPTION CUSTOMER POWER/SIGNAL PROFINET, IRB460/760/4600/6xx0/7600		9/11/2024	CNYAZHA48	
32	OPTION CUSTOMER POWER/SIGNAL DEVICENET, IRB460/760/4600/6xx0/7600		9/11/2024	CNYAZHA48	
33	Revision information		9/11/2024	CNYAZHA48	

we reserve all rights in this document and in the information contained herein (reproduction, use or disclosure to third parties without express authority is strictly forbidden). © Copyright 2003 ABB

Latest revision: ECN000379753			Lab/Office: IRT 710	Status: APPROVED	Plant: =
Prepared by, date: CNYAZHA48,2024-09-15	Approved by, date: CNFALEG,20240920		Table of contents : 1 - 33	Document no. 3HKA00000191004002	Location: + Sublocation: +
				Rev. Ind	Page 3
					Next 4
					Total 33

IRC5



XS7	XP7
XS1	XP1
XS2	XP2

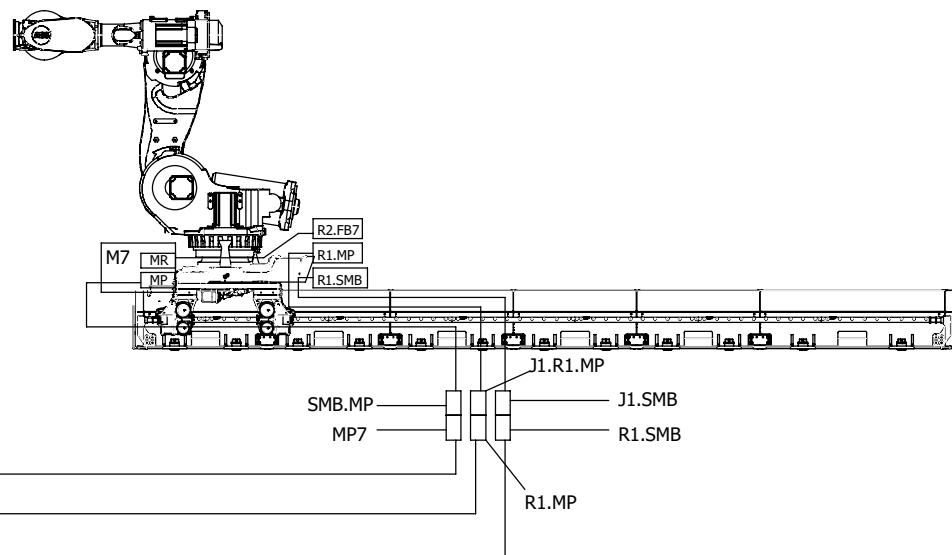

* SYSTEM CONFIGURATION

MOTOR No.	SMB NODE No.	UNIT
M7	7	IRB

3

5

Responsible Department: RATY - RD		Design by: Yan Zhang		IRT 710		ABB	BLOCK DIAGRAM IRB SMB CONNECTION for IRB4600, 6620,6650s,6660,6700,660,760,7600		Status: Approved		=
Prepare by,Date:CNVAZHA48,20240915		Approve by,Date:CNFALEG,20240920		Replacement of	Replaced by		Document no. 3HKA00000191004		Rev.Ind		+
										Page	4
										Total Page	33

We reserve all rights in this document and in the information contained therein. Reproduction, use or disclosure to third parties without express authority is strictly forbidden. Copyright ABB

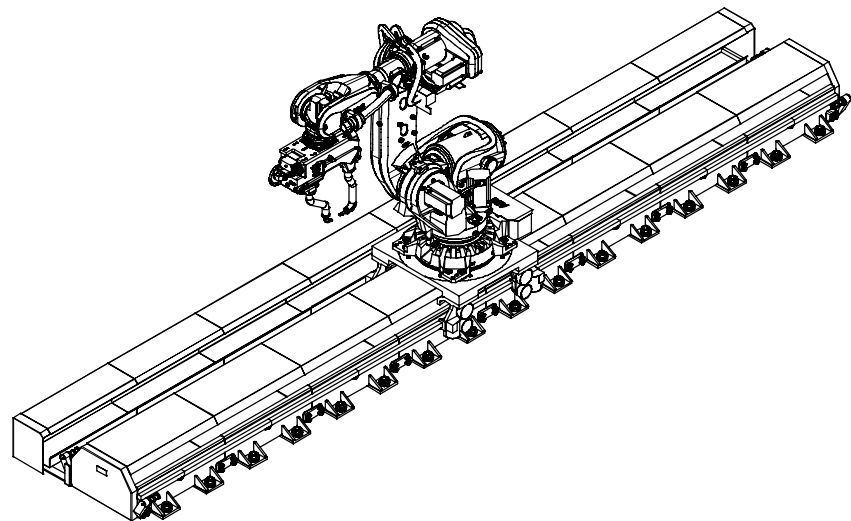

* SYSTEM CONFIGURATION

MOTOR No.	SMB NODE No.	UNIT
M7	7	SMB BOX
M8	7	IRB



XS7	X7
XS41	XP2/XP41
XS1	XP1
XS2	XP2

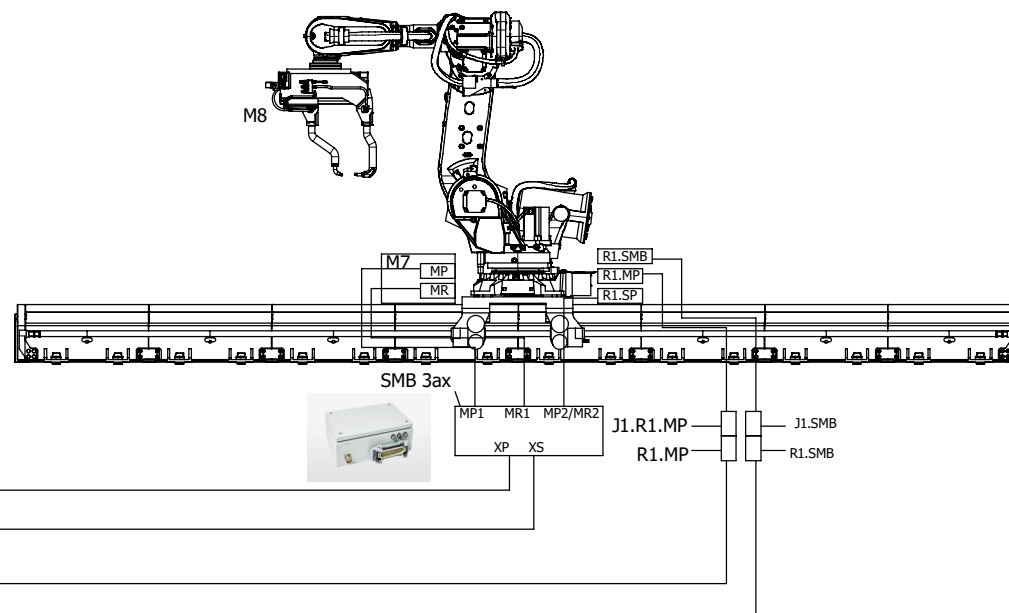

Responsible Department: RATY - RD	Design by: Yan Zhang
Prepare by, Date: CNYAZHA48, 20240915	Approve by, Date: CNFALEG, 20240920

IRT 710	
Replacement of	Replaced by



BLOCK DIAGRAM CONNECTION
for IRB6620, 6650S, 6660,
6700, 7600 (spot welding)

Status:
Approved
Document no.
3HKA00000191004

Rev.Ind	Page
+	5
Total Page 33	

* SYSTEM CONFIGURATION

MOTOR No.	SMB NODE No.	UNIT
M7	7	SMB BOX



IRC5

XS41	XP2/XP41
XS7	XP7
XS1	XP1
XS2	XP2

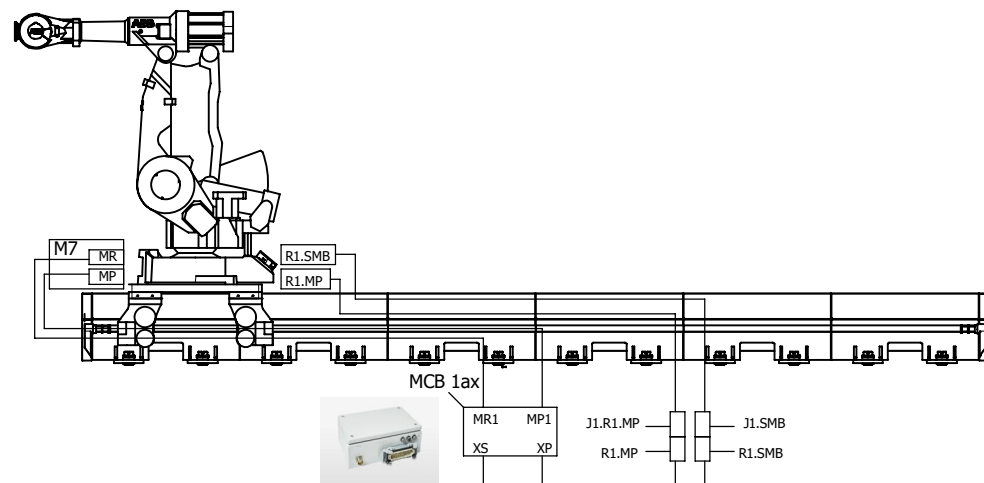

Responsible Department: RATY - RD	Design by: Yan Zhang
Prepare by,Date:CNVAZHA48,20240915	Approve by,Date:CNFALEG,20240920

IRT 710	Replacement of	Replaced by
---------	----------------	-------------



BLOCK DIAGRAM
IRT SMB BOX CONNECTION IRB4400
IRB460

Status: **Approved**
Document no. **3HKA00000191004**

Rev.Ind	Page
+	6
Total Page 33	

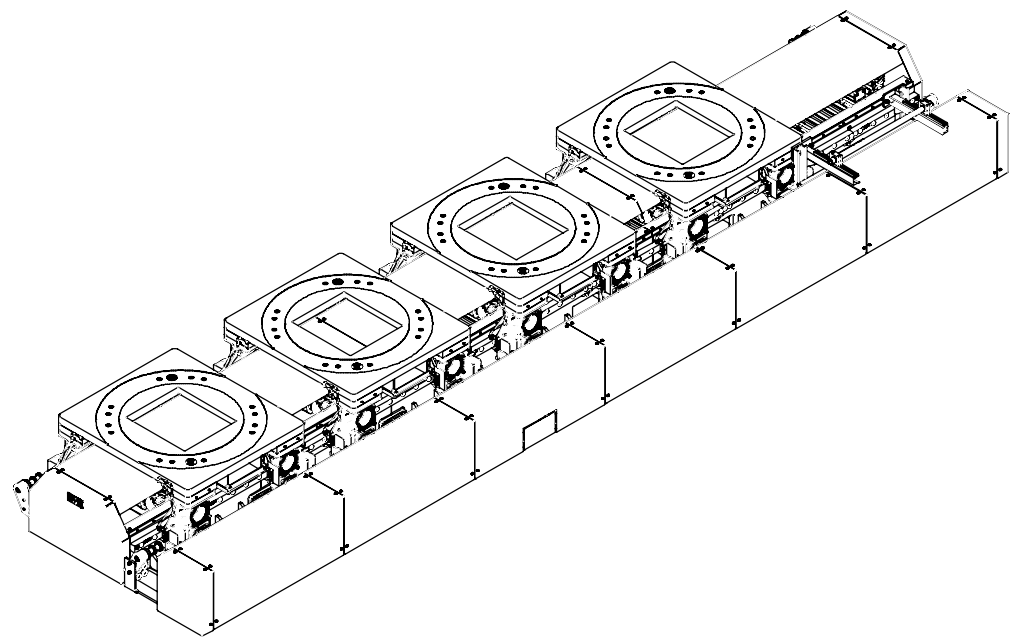

* SYSTEM CONFIGURATION

MOTOR No.	SMB NODE No.	UNIT
M1	1	SMB BOX 1
M2(OPTION)	3	SMB BOX 1
M3(OPTION)	5	SMB BOX 1
M4(OPTION)	7	SMB BOX 2

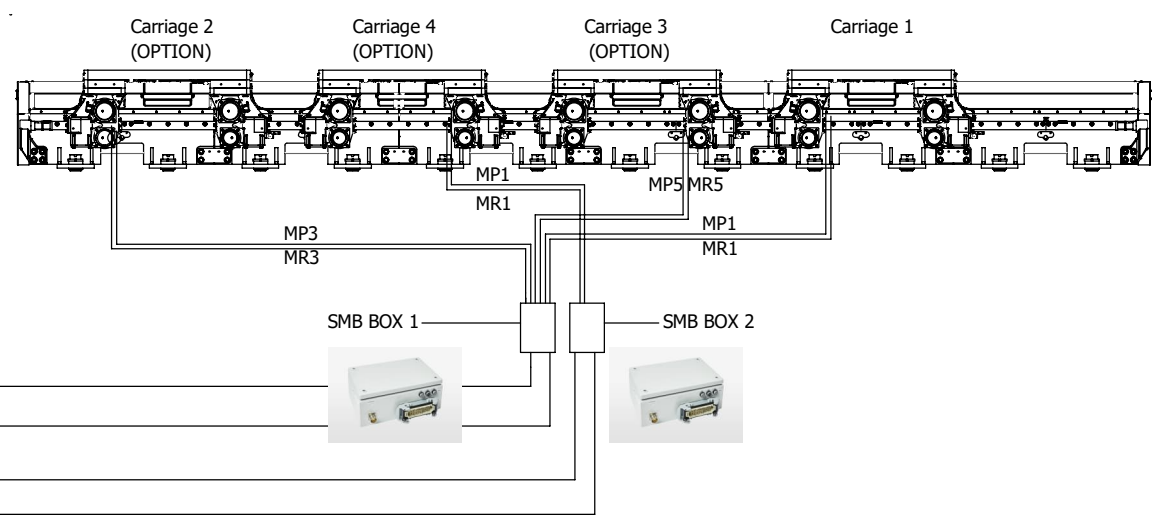

IRC5

XS1	XP1
XS2	XP2
XS7	XP7
XS41	XP41

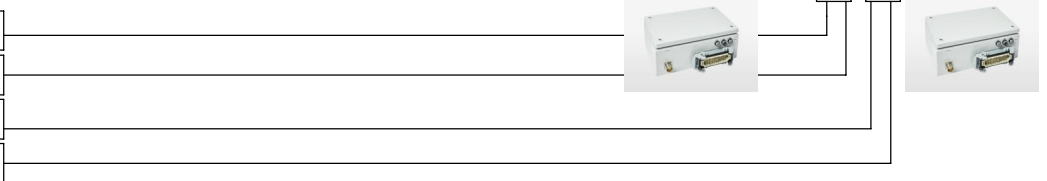

Responsible Department: RATY - RD	Design by: Yan Zhang
Prepare by, Date: CNYAZHA48, 20240915	Approve by, Date: CNFALEG, 20240920

IRT 710	
Replacement of	Replaced by



BLOCK DIAGRAM
IRT SMB BOX CONNECTION TRANSFER
CARRIAGE

Status: **Approved**
Document no. **3HKA00000191004**

Rev.Ind	Page
+	7
Total Page 33	

We reserve all rights in this document and in the information contained therein. Reproduction, use or disclosure to third parties without express authority is strictly forbidden. Copyright ABB

SEE EL. DRAWINGS FOR THE
ROBOT CONTROL SYSTEM

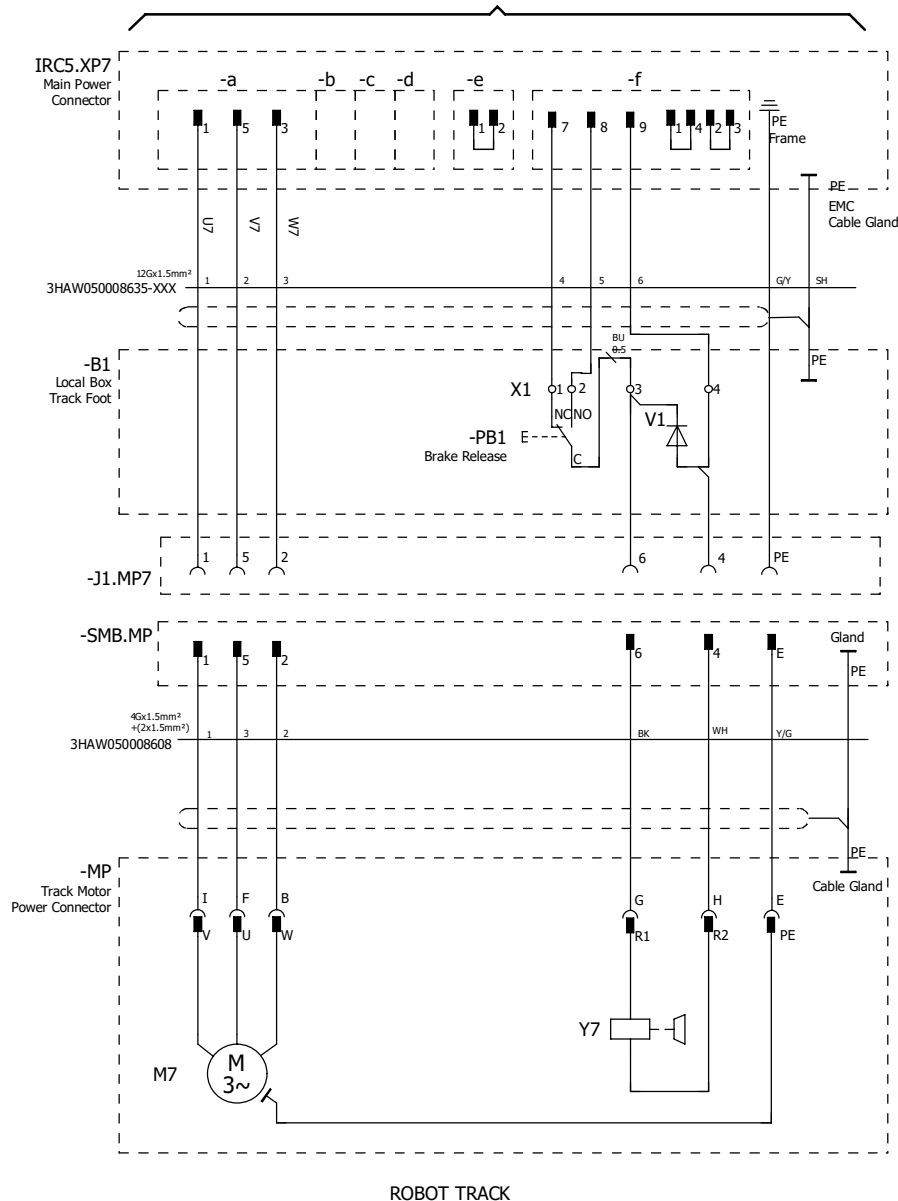

7

9

Responsible Department: RATY - RD	Design by: Yan Zhang
Prepare by, Date: CNYAZHA48, 20240915	Approve by, Date: CNFALEG, 20240920

IRT 710	
Replacement of	Replaced by



MOTOR IRT, IRB4600/660/
6620/6650S/6660/6700/760/7600

Status: **Approved**
Document no. **3HKA00000191004**

Rev.Ind	Page
8	8
Total Page 33	

We reserve all rights in this document and in the information contained therein. Reproduction, use or disclosure to third parties without express authority is strictly forbidden. Copyright ABB

SEE EL. DRAWINGS FOR THE ROBOT CONTROL SYSTEM

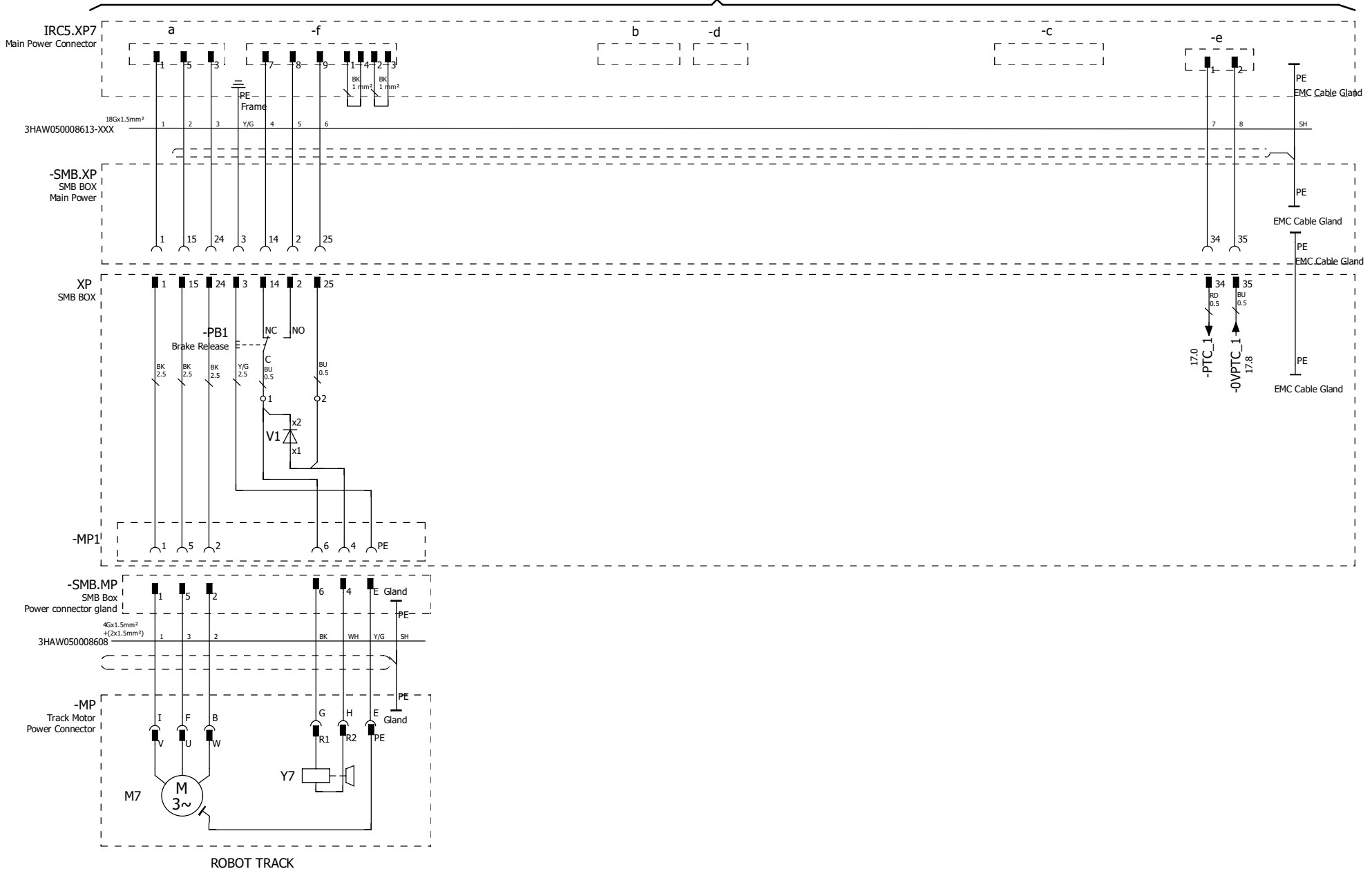

ROBOT TRACK

8

10

Responsible Department: RATY - RD		Design by: Yan Zhang		IRT 710		ABB		MOTOR IRT, IRB460/4400		Status: Approved		=	
Prepare by,Date:CNVAZHA48,20240915		Approve by,Date:CNFALEG,20240920		Replacement of		Replaced by				Document no. 3HKA00000191004		+	
										Rev.Ind		Page 9	
												Total Page 33	

SEE EL. DRAWINGS FOR THE
ROBOT CONTROL SYSTEM

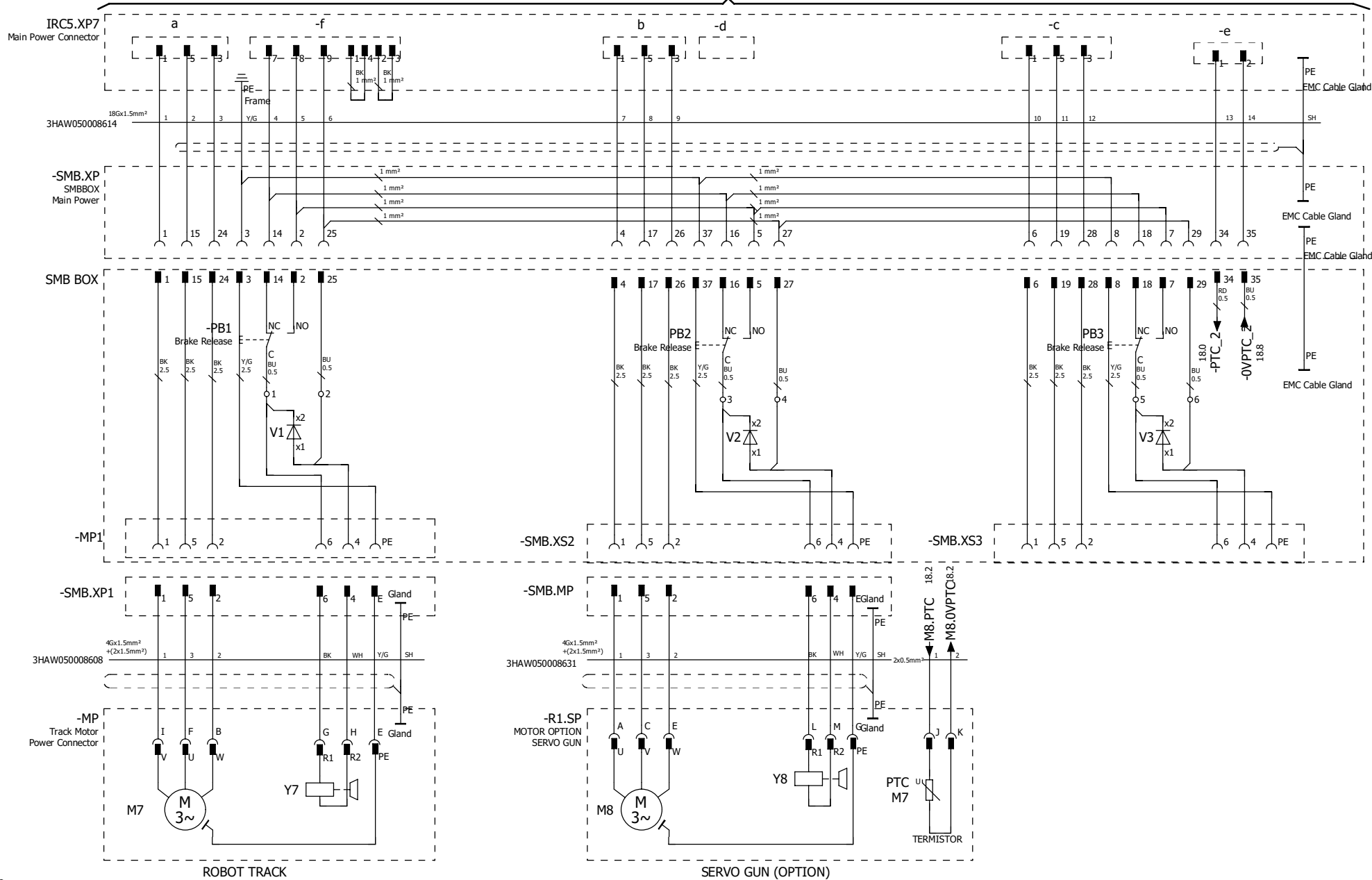

ROBOT TRACK

SERVO GUN (OPTION)

9

Responsible Department: RATY - RD		Design by: Yan Zhang		IRT 710		Status: Approved		=	
Prepare by,Date:CNYZHA48,20240915		Approve by,Date:CNFALEG,20240920		Replacement of		MOTOR IRT, OPTION SERVO GUN		+ Document no. 3HKA00000191004	
				Replaced by				Rev.Ind Page 10	
								Total Page 33	



We reserve all rights in this document and in the information contained therein. Reproduction, use or disclosure to third parties without express authority is strictly forbidden. Copyright ABB

11

We reserve all rights in this document and in the information contained therein. Reproduction, use or disclosure to third parties without express authority is strictly forbidden. Copyright ABB

SEE EL. DRAWINGS FOR THE ROBOT CONTROL SYSTEM

SEE EL. DRAWINGS FOR THE ROBOT CONTROL SYSTEM

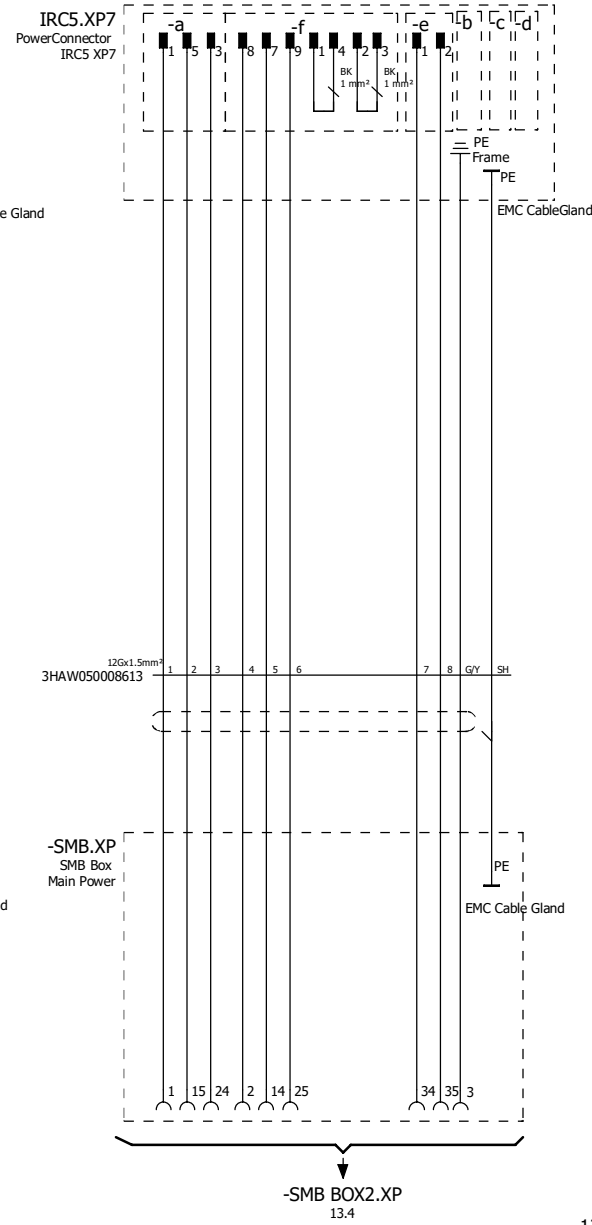
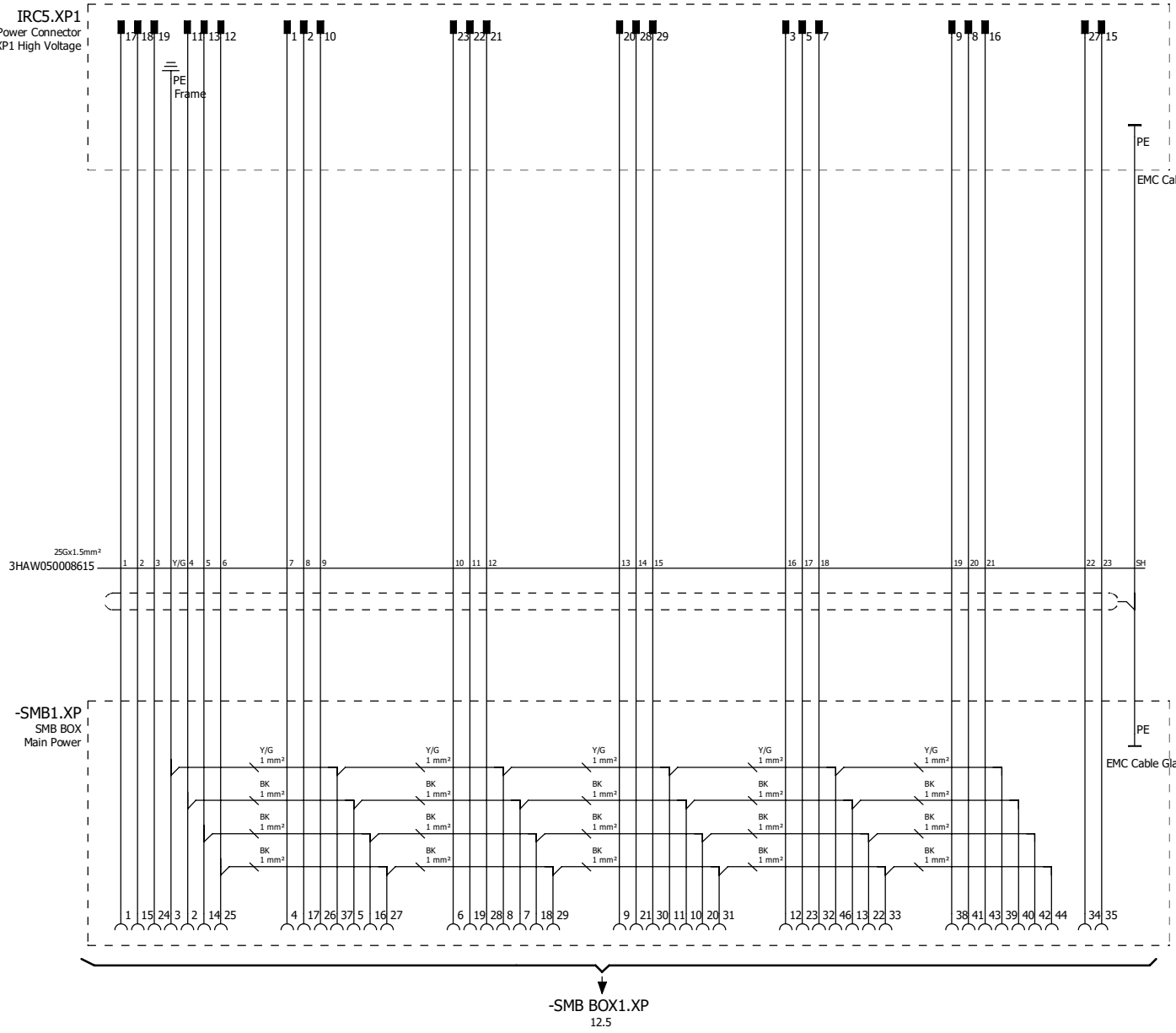

10

12

Responsible Department: RATY - RD	Design by: Yan Zhang
Prepare by, Date: CNYAZHA48, 20240915	Approve by, Date: CNFALEG, 20240920

IRT 710	
Replacement of	Replaced by



MOTOR IRT, TRANSFER CARRIAGE
STATIC CABLE

Status: Approved	=
Document no. 3HKA00000191004	+
Rev. Ind	Page 11
	Total Page 33

We reserve all rights in this document and in the information contained therein. Reproduction, use or disclosure to third parties without express authority is strictly forbidden. Copyright ABB

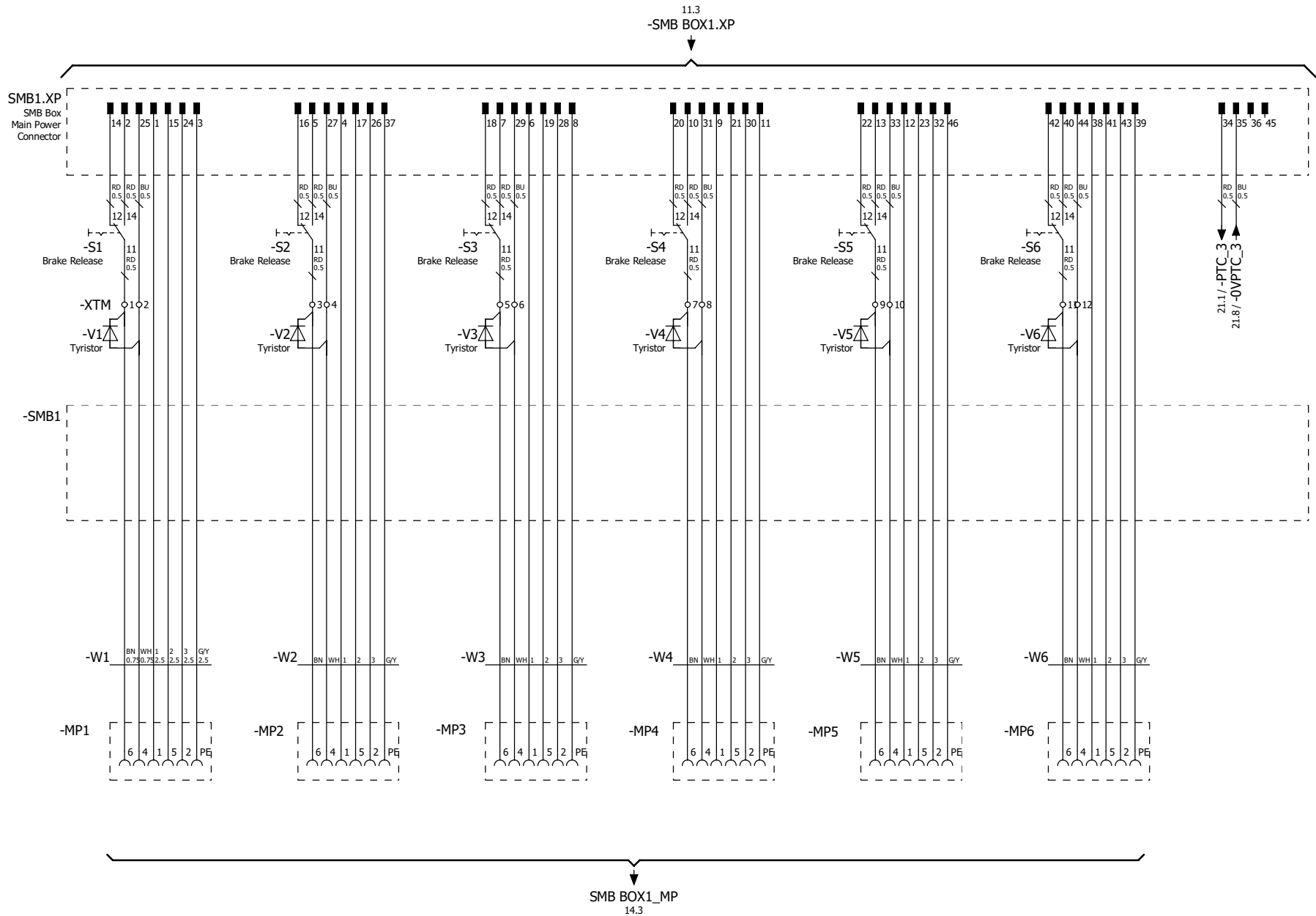

Responsible Department: RATY - RD	Design by: Yan Zhang
Prepare by, Date: CNYAZHA48, 20240915	Approve by, Date: CNFALEG, 20240920

IRT 710	
Replacement of	Replaced by



MOTOR IRT, TRANSFER CARRIAGE SMB
1(6 Axes)

Status: **Approved**
Document no.
3HKA00000191004

=	
+	
Rev.Ind	Page 12
	Total Page 33

We reserve all rights in this document and in the information contained therein. Reproduction, use or disclosure to third parties without express authority is strictly forbidden. Copyright ABB

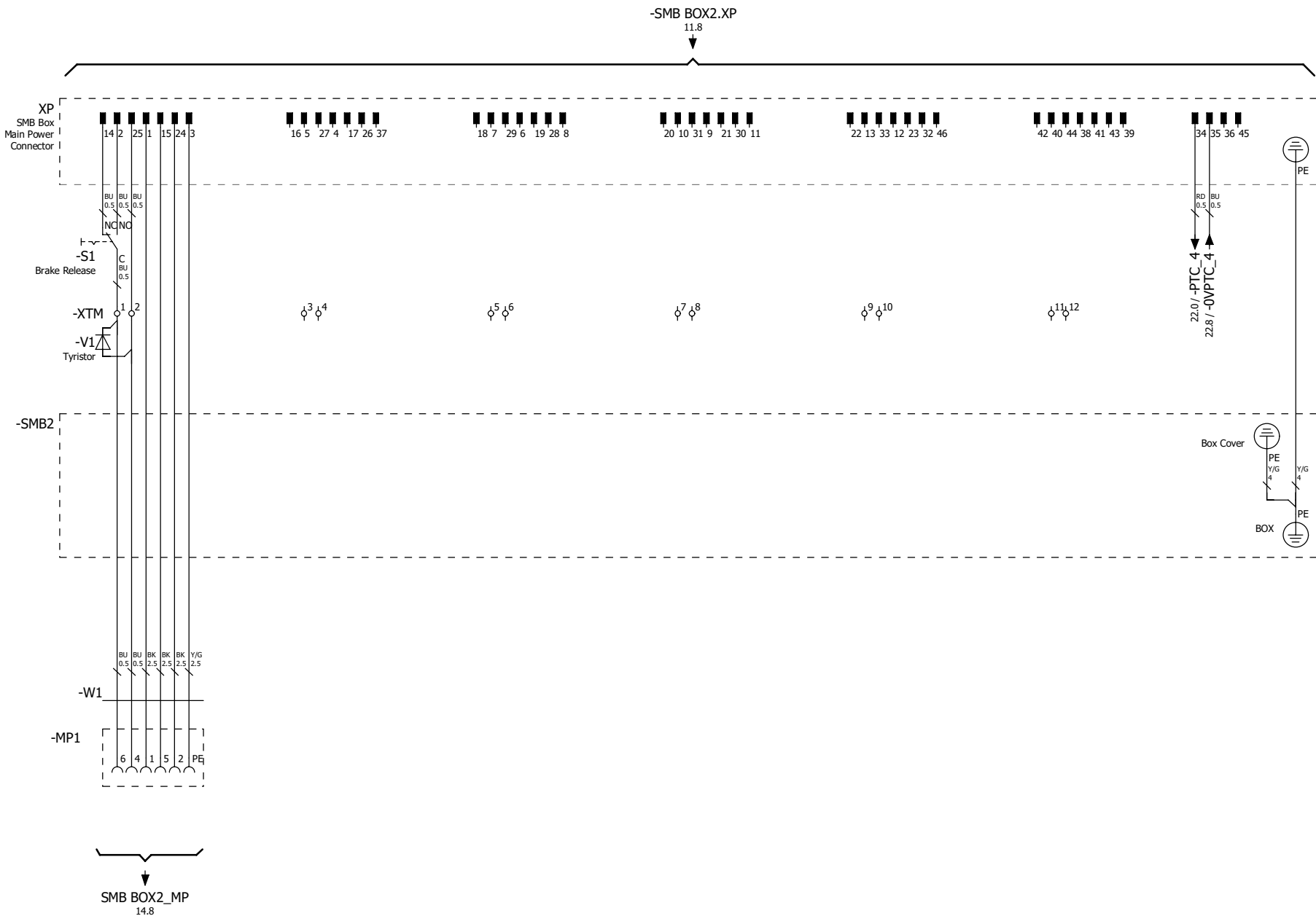

Responsible Department: RATY - RD	Design by: Yan Zhang
Prepare by, Date: CNYAZHA48, 20240915	Approve by, Date: CNFALEG, 20240920

IRT 710	
Replacement of	Replaced by



MOTOR IRT, TRANSFER CARRIAGE SMB
2(1 Axes)

Status: **Approved**
Document no. **3HKA00000191004**

Rev.Ind	Page 13
	Total Page 33

We reserve all rights in this document and in the information contained therein. Reproduction, use or disclosure to third parties without express authority is strictly forbidden. Copyright ABB

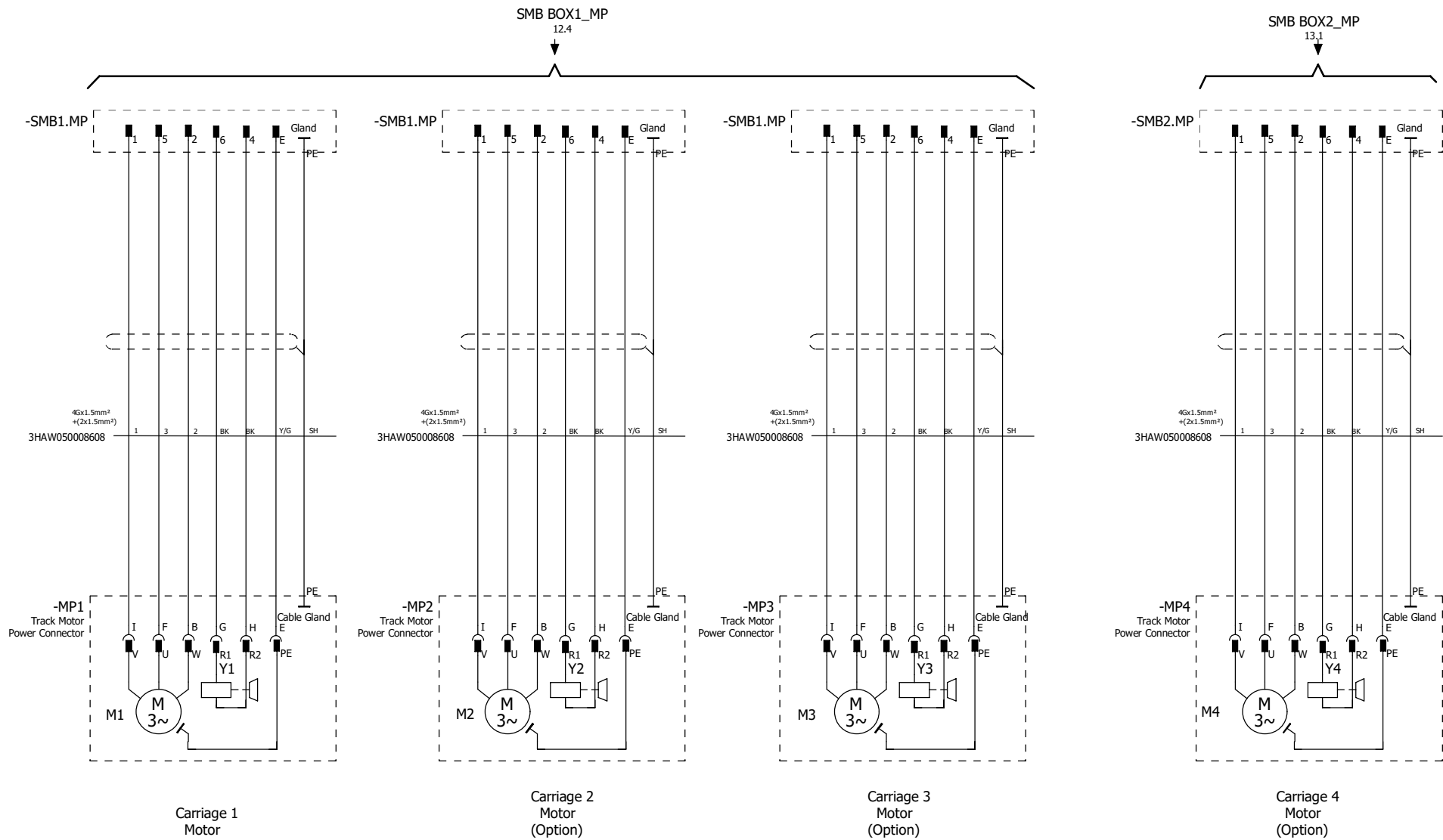

Responsible Department: RATY - RD		Design by: Yan Zhang		IRT 710		MOTOR IRT, TRANSFER CARRIAGE MOTOR		Status: Approved		=	
Prepare by,Date: CNYAZHA48,20240915		Approve by,Date: CNFALEG,20240920		Replacement of		Replaced by		Document no. 3HKA00000191004		+	
								Rev.Ind		Page 14	
										Total Page 33	



SEE EL. DRAWINGS FOR THE
ROBOT MANIPULATOR SYSTEM

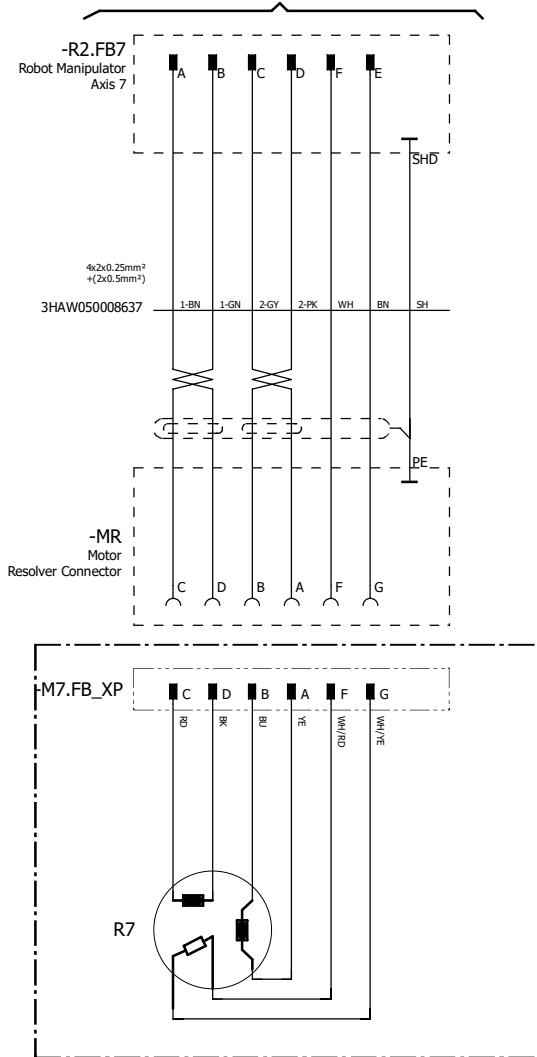

ROBOT TRACK

Responsible Department: RATY - RD	Design by: Yan Zhang
Prepare by, Date: CNYAZHA48, 20240915	Approve by, Date: CNFALEG, 20240920

IRT 710	Replacement of	Replaced by
---------	----------------	-------------



MOTOR RESOLVER,
IRB46x0/6xx0/760/7600

Status:
Approved
Document no.
3HKA00000191004

Rev.Ind	Page 15	Total Page 33
---------	---------	---------------

SEE EL. DRAWINGS FOR THE
ROBOT CONTROL SYSTEM

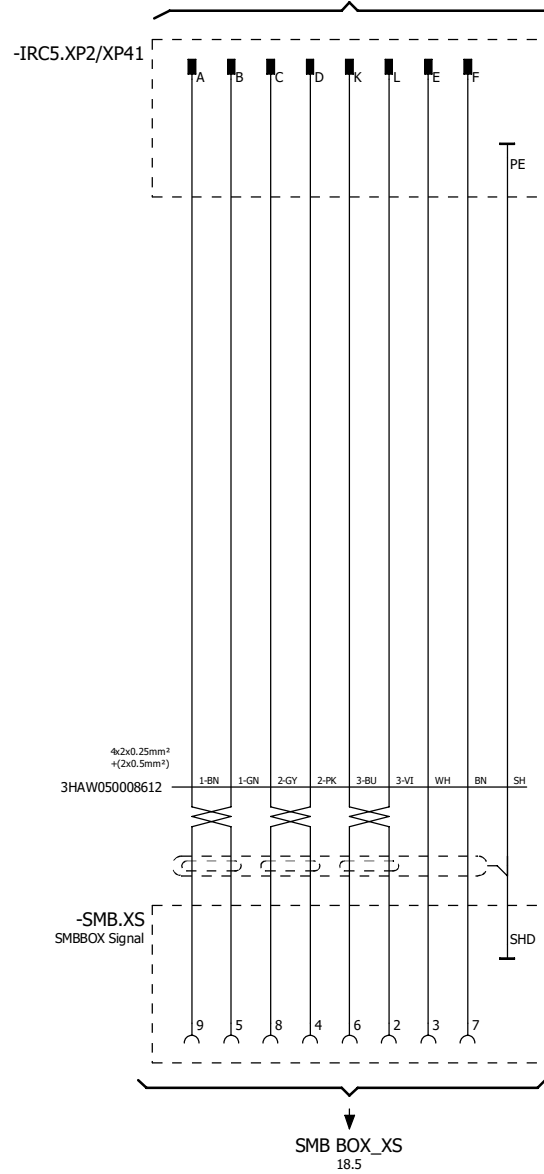

We reserve all rights in this document and in the information contained therein. Reproduction, use or disclosure to third parties without express authority is strictly forbidden. Copyright ABB

Responsible Department: RATY - RD	Design by: Yan Zhang
Prepare by, Date: CNYAZHA48, 20240915	Approve by, Date: CNFALEG, 20240920

IRT 710	
Replacement of	Replaced by



MOTOR RESOLVER STATIC CABLE

Status: **Approved**
Document no. **3HKA00000191004**

Rev.Ind	Page 16
	Total Page 33

We reserve all rights in this document and in the information contained therein. Reproduction, use or disclosure to third parties without express authority is strictly forbidden. Copyright ABB

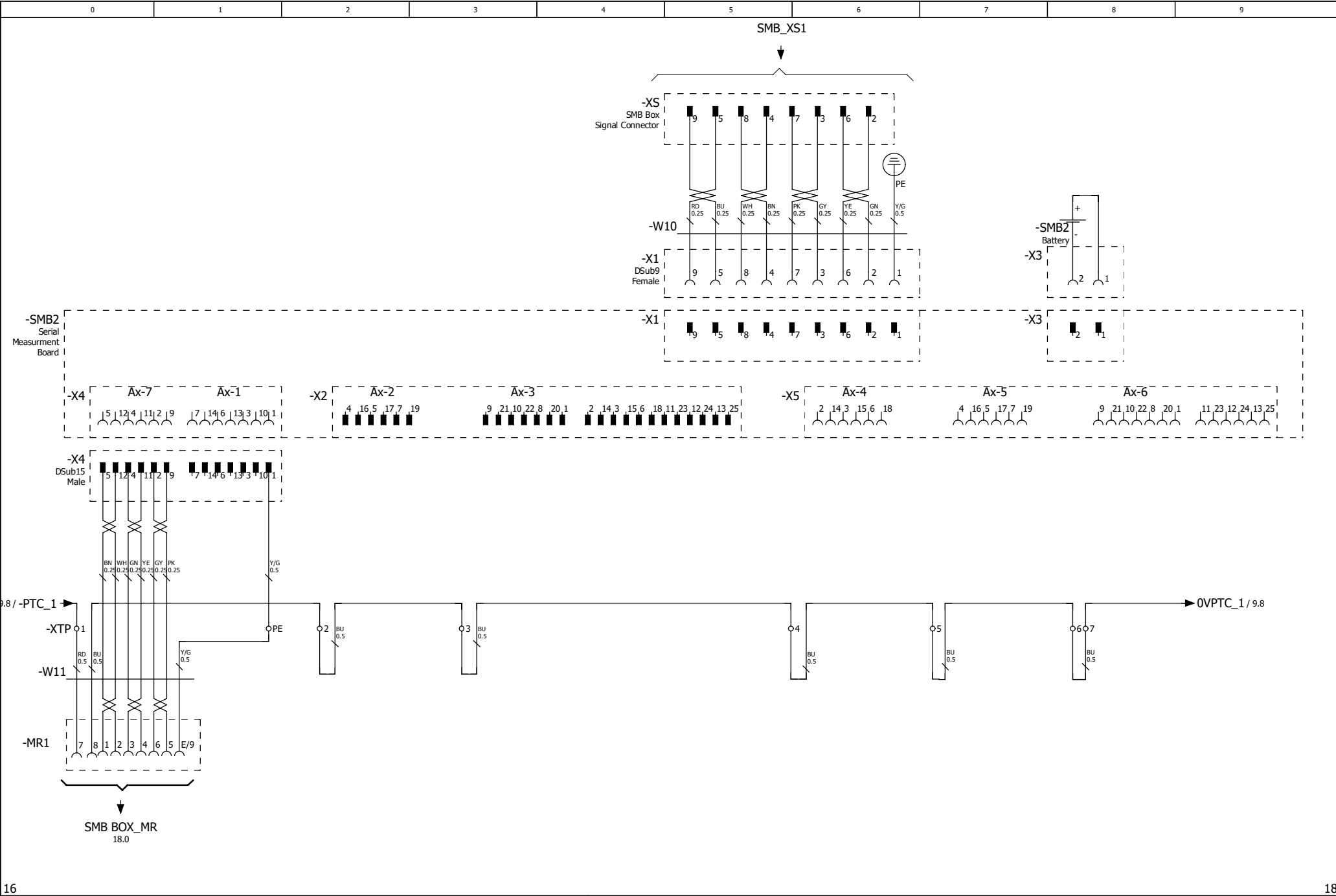

Responsible Department: RATY - RD		Design by: Yan Zhang		IRT 710		ABB	MOTOR RESOLVER, IRB4400, IRB460		Status: Approved		=	
Prepare by, Date: CNYAZHA48, 20240915		Approve by, Date: CNFALEG, 20240920		Replacement of			Replaced by		Document no. 3HKA00000191004		+ Rev.Ind	
										Page 17	Total Page 33	

We reserve all rights in this document and in the information contained therein. Reproduction, use or disclosure to third parties without express authority is strictly forbidden. Copyright ABB

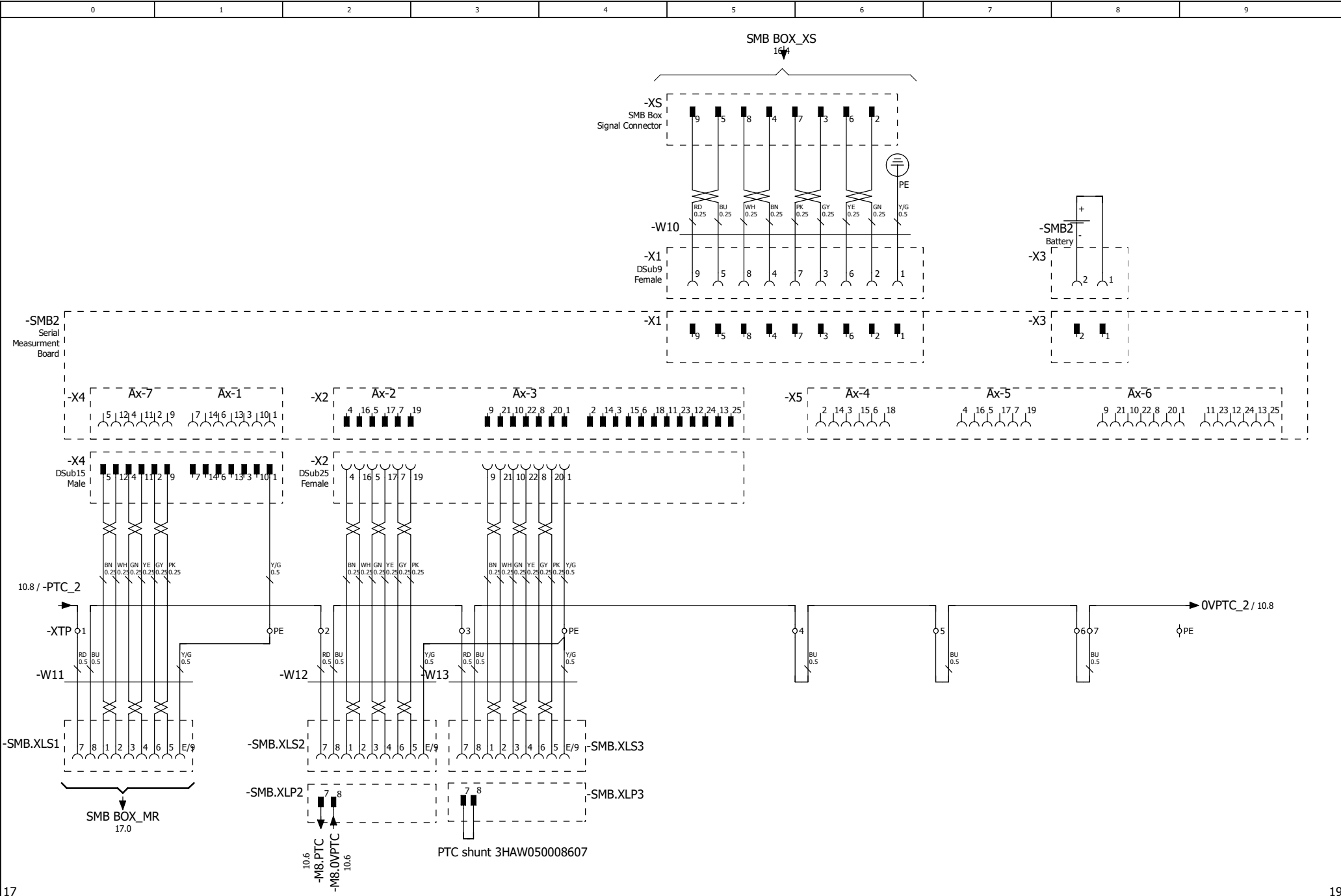

Responsible Department: RATY - RD Design by: Yan Zhang Prepare by, Date: CNYAZHA48, 20240915 Approve by, Date: CNFALEG, 20240920	IRT 710 Replacement of _____ Replaced by _____		MOTOR RESOLVER, OPTION SERVO GUN	Status: Approved Document no. 3HKA00000191004	= +	Rev.Ind Page 18 Total Page 33
---	---	--	---	--	--------	-------------------------------------

We reserve all rights in this document and in the information contained therein. Reproduction, use or disclosure to third parties without express authority is strictly forbidden. Copyright ABB

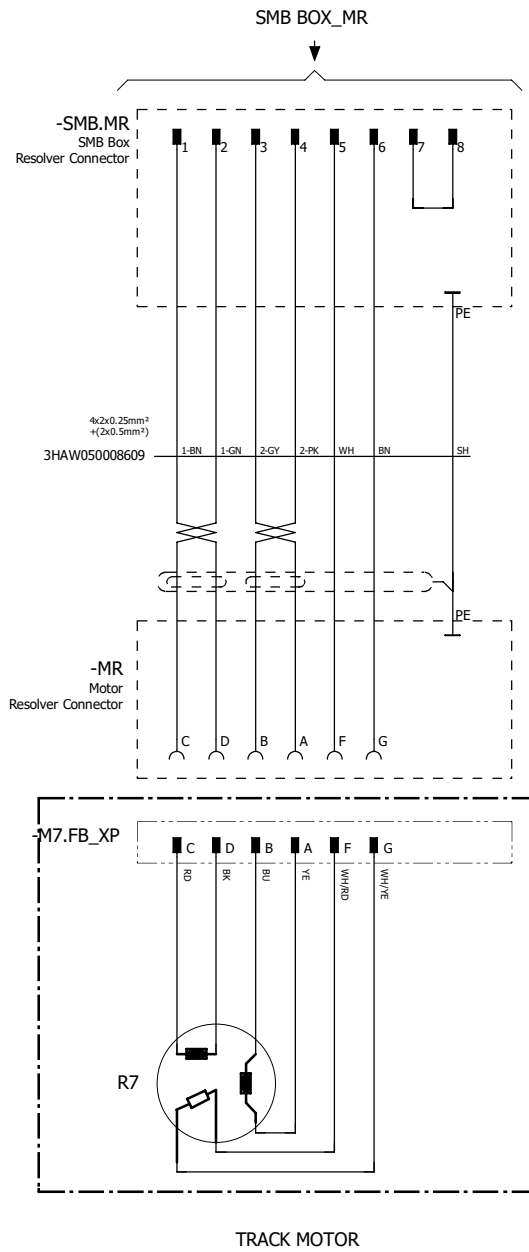

Responsible Department: RATY - RD	Design by: Yan Zhang
Prepare by, Date: CNYAZHA48, 20240915	Approve by, Date: CNFALEG, 20240920

IRT 710	
Replacement of	Replaced by



MOTOR RESOLVER CONNECTION

Status: **Approved**
 Document no. 3HKA00000191004

=	
+	
Rev.Ind	Page
Total Page	33

We reserve all rights in this document and in the information contained therein. Reproduction, use or disclosure to third parties without express authority is strictly forbidden. Copyright ABB

SEE EL. DRAWINGS FOR THE ROBOT CONTROL SYSTEM

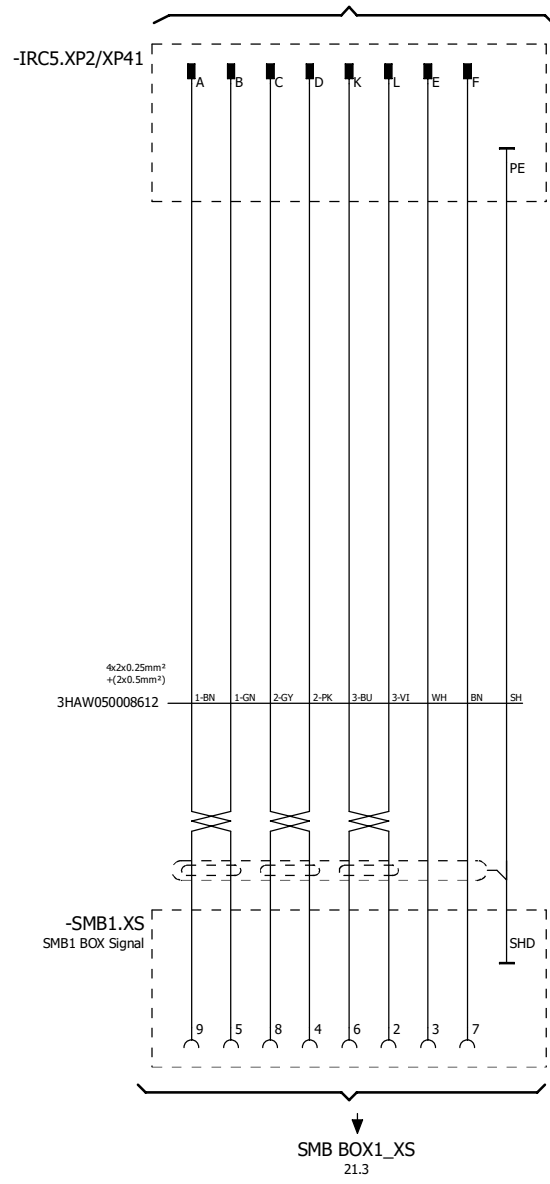

SEE EL. DRAWINGS FOR THE ROBOT CONTROL SYSTEM

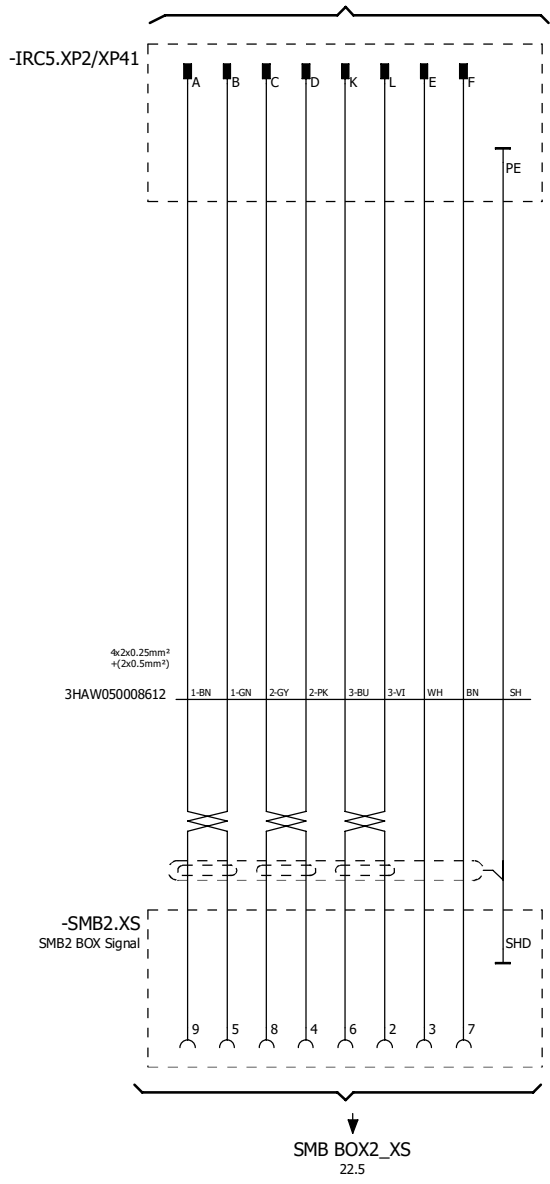

Responsible Department: RATY - RD	Design by: Yan Zhang
Prepare by, Date: CNYAZHA48, 20240915	Approve by, Date: CNFALEG, 20240920

IRT 710	
Replacement of	Replaced by



MOTOR RESOLVER, TRANSFER
CARRIAGE STATIC CABLE

Status:
Approved
Document no.
3HKA00000191004

Rev.Ind	Page 20
	Total Page 33

We reserve all rights in this document and in the information contained therein. Reproduction, use or disclosure to third parties without express authority is strictly forbidden. Copyright ABB

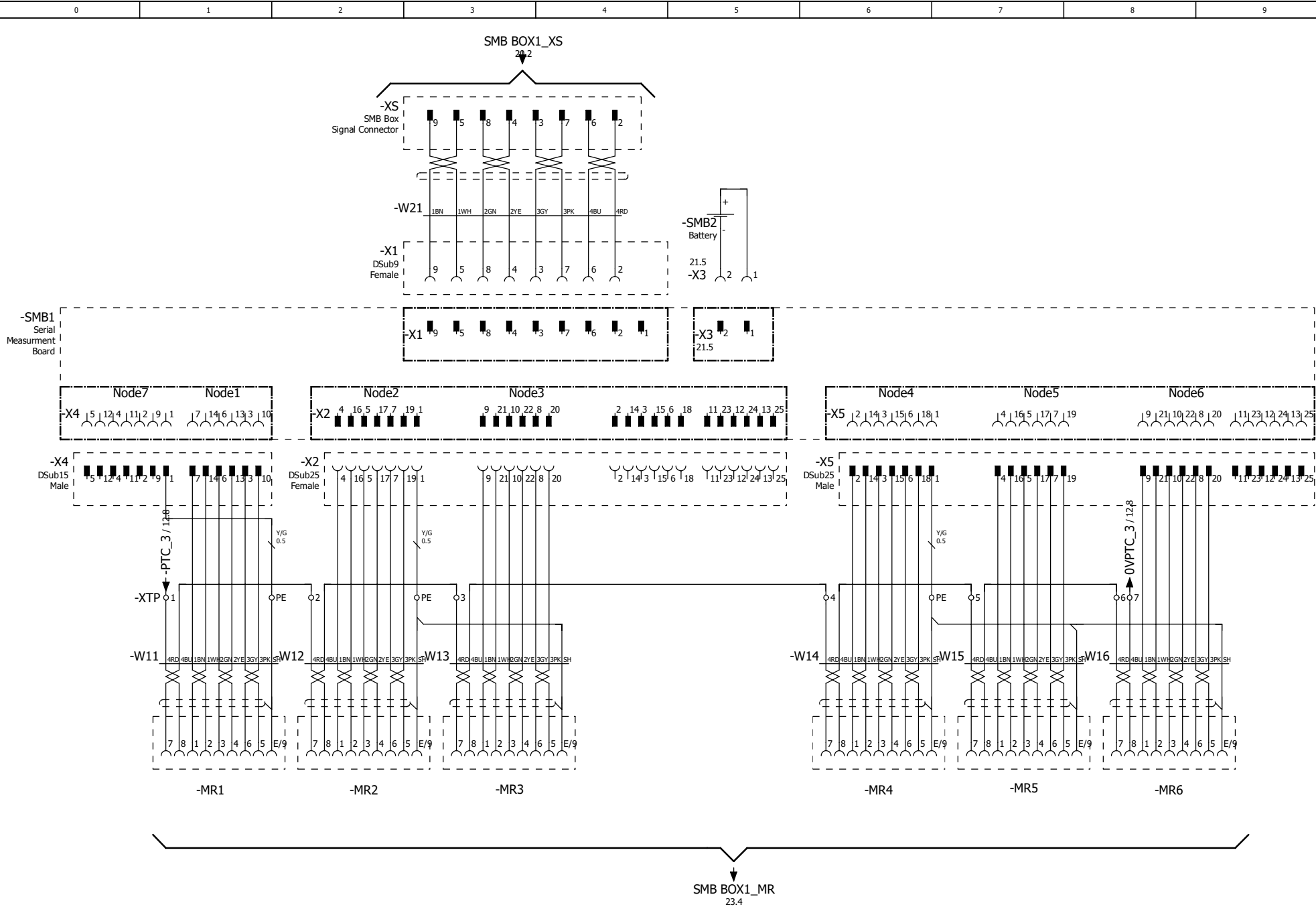

Responsible Department: RATY - RD	Design by: Yan Zhang
Prepare by, Date: CNYAZHA48, 20240915	Approve by, Date: CNFALEG, 20240920

IRT 710	
Replacement of	Replaced by



MOTOR RESOLVER, TRANSFER CARRIAGE SMB 1(6Axes)

Status: Approved
 Document no. 3HKA00000191004

Rev.Ind	Page 21
	Total Page 33

We reserve all rights in this document and in the information contained therein. Reproduction, use or disclosure to third parties without express authority is strictly forbidden. Copyright ABB

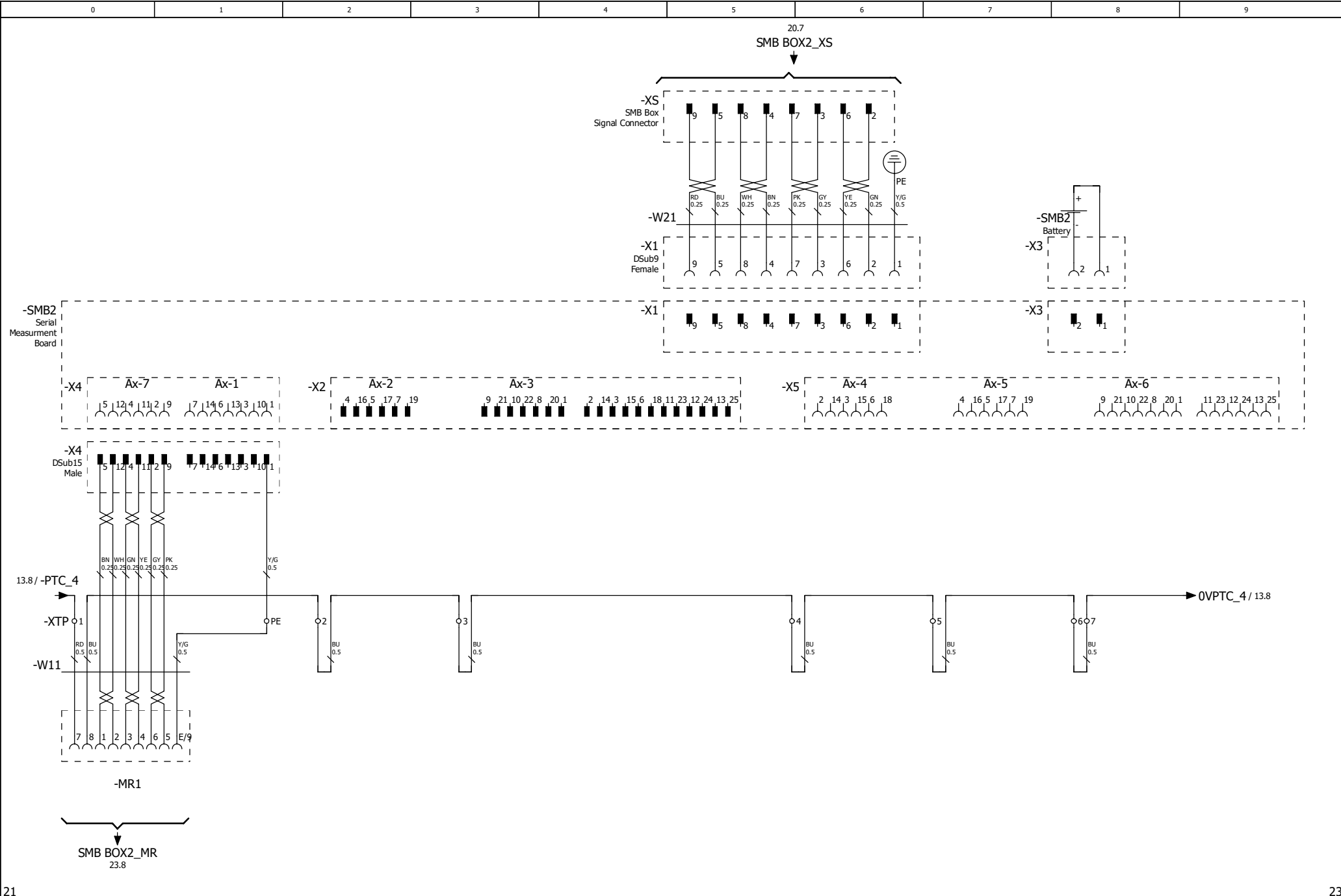

21

Responsible Department: RATY - RD Design by: Yan Zhang		IR7 710		ABB	MOTOR RESOLVER, TRANSFER CARRIAGE SMB 2(1Axes)	Status: Approved	=
Prepare by,Date:CNVAZHA48,20240915 Approve by,Date:CNFALEG,20240920		Replacement of	Replaced by			Document no. 3HKA00000191004	Rev.Ind
						Total Page 33	

23

We reserve all rights in this document and in the information contained therein. Reproduction, use or disclosure to third parties without express authority is strictly forbidden. Copyright ABB

SMB BOX1_MR
21.5

SMB BOX2_MR
22.0

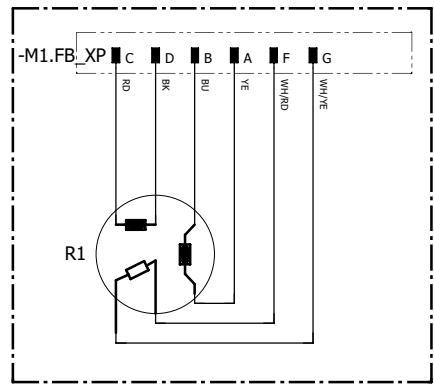
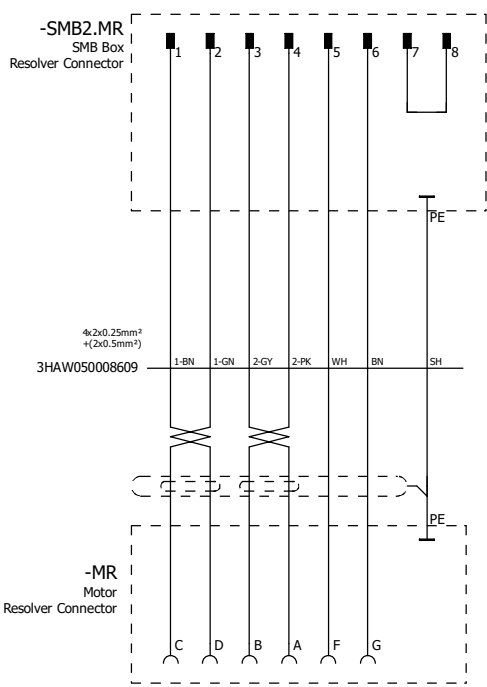
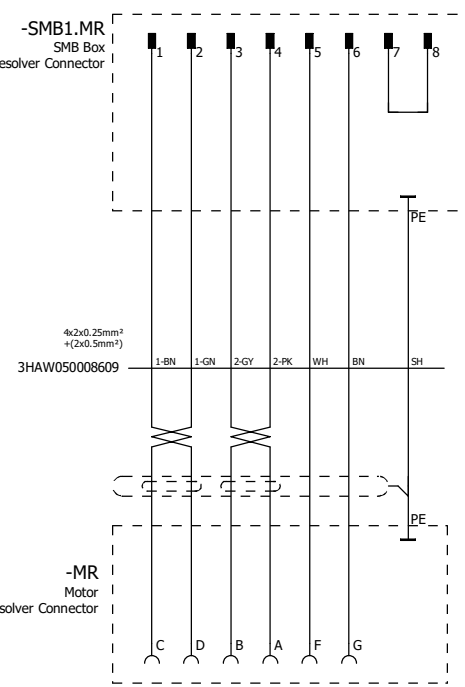
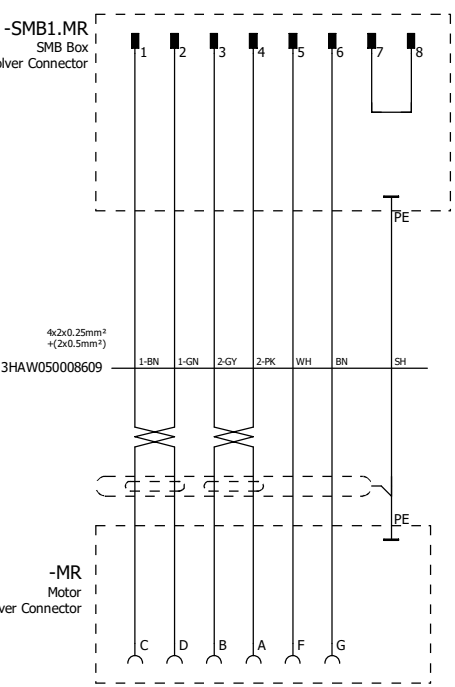
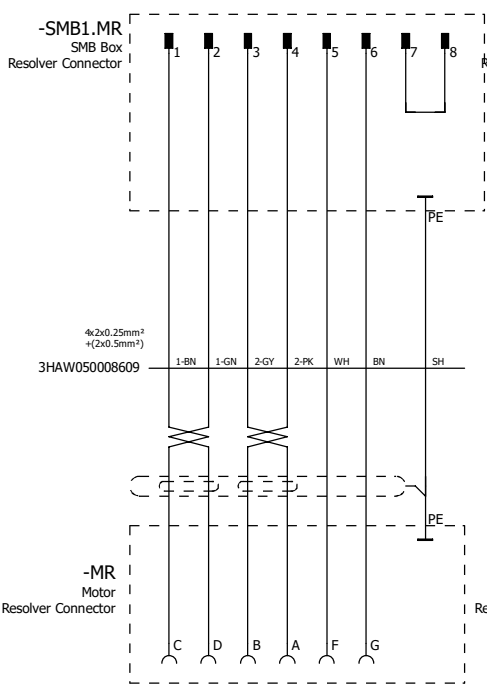

Carriage 1
Motor Resolver

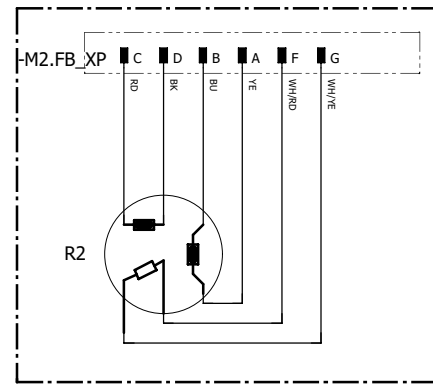

Carriage 2
Motor Resolver
(Option)

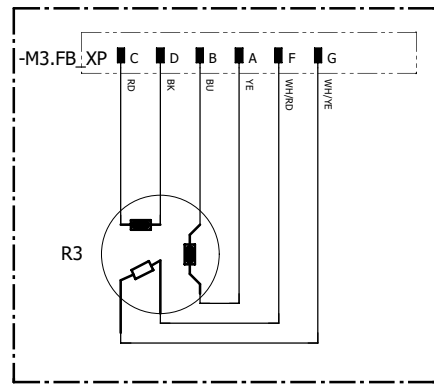

Carriage 3
Motor Resolver
(Option)

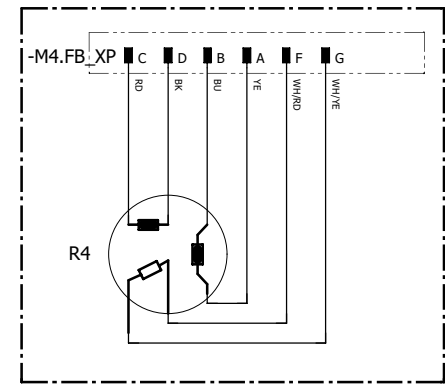

Carriage 4
Motor Resolver
(Option)

Responsible Department: RATY - RD	Design by: Yan Zhang
Prepare by, Date: CNYAZHA48, 20240915	Approve by, Date: CNFALEG, 20240920

IRT 710	
Replacement of	Replaced by



MOTOR RESOLVER, TRANSFER
CARRIAGE MOTOR

Status:
Approved
Document no.
3HKA00000191004

Rev.Ind	Page 23
	Total Page 33

We reserve all rights in this document and in the information contained therein. Copyright ABB. Reproduction, use or disclosure to third parties without express authority is strictly forbidden.

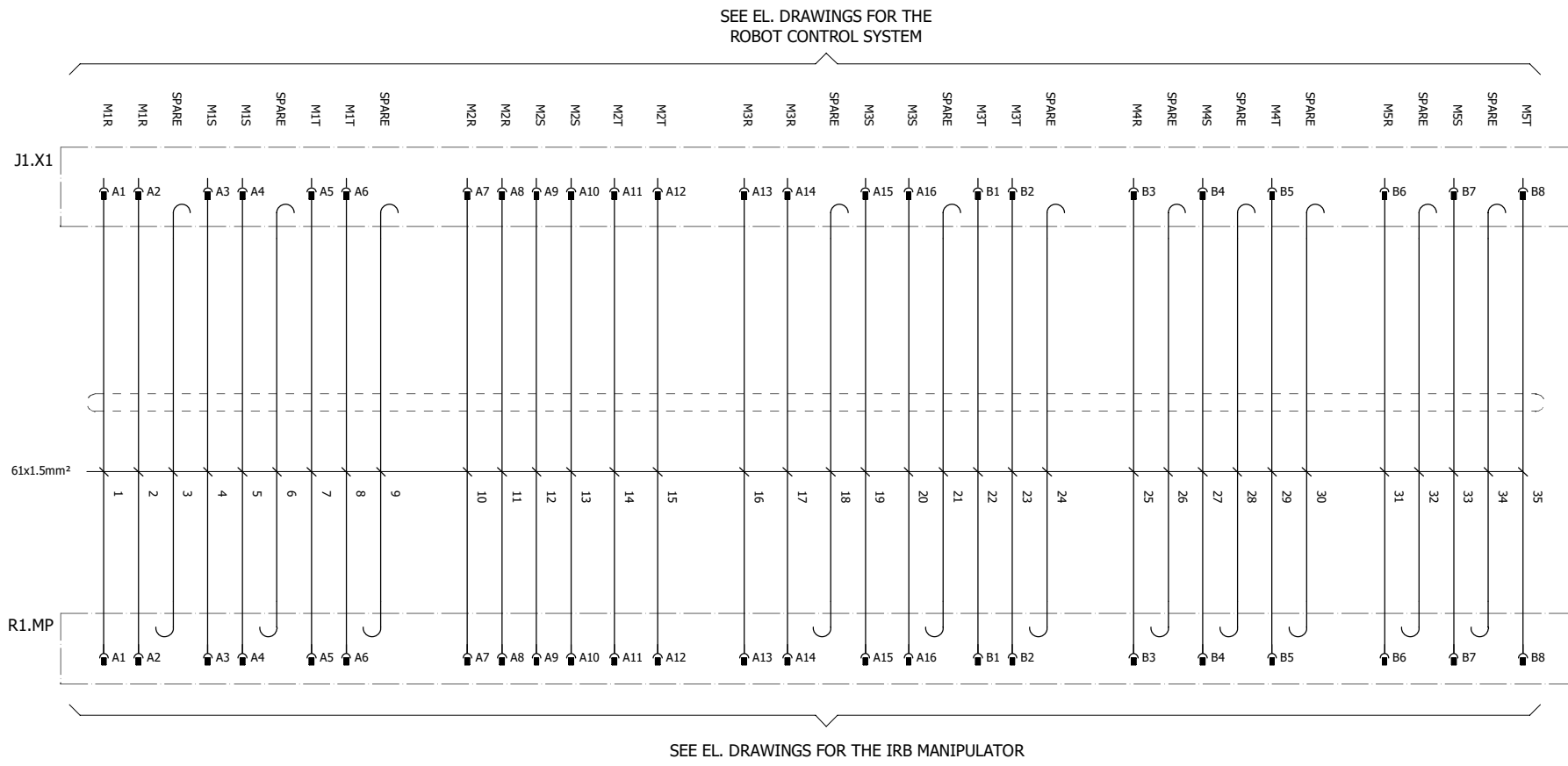

Responsible Department: RATY - RD Design by: Yan Zhang Prepare by, Date: CNYAZHA48, 20240915 Approve by, Date: CNFALEG, 20240920	IRT 710		MOTOR CABLE, IRB4400	Status: Approved Document no. 3HKA00000191004	= +	Rev.Ind Page 24 Total Page 33
Replacement of	Replaced by					

We reserve all rights in this document and in the information contained therein. Reproduction, use or disclosure to third parties without express authority is strictly forbidden. Copyright ABB

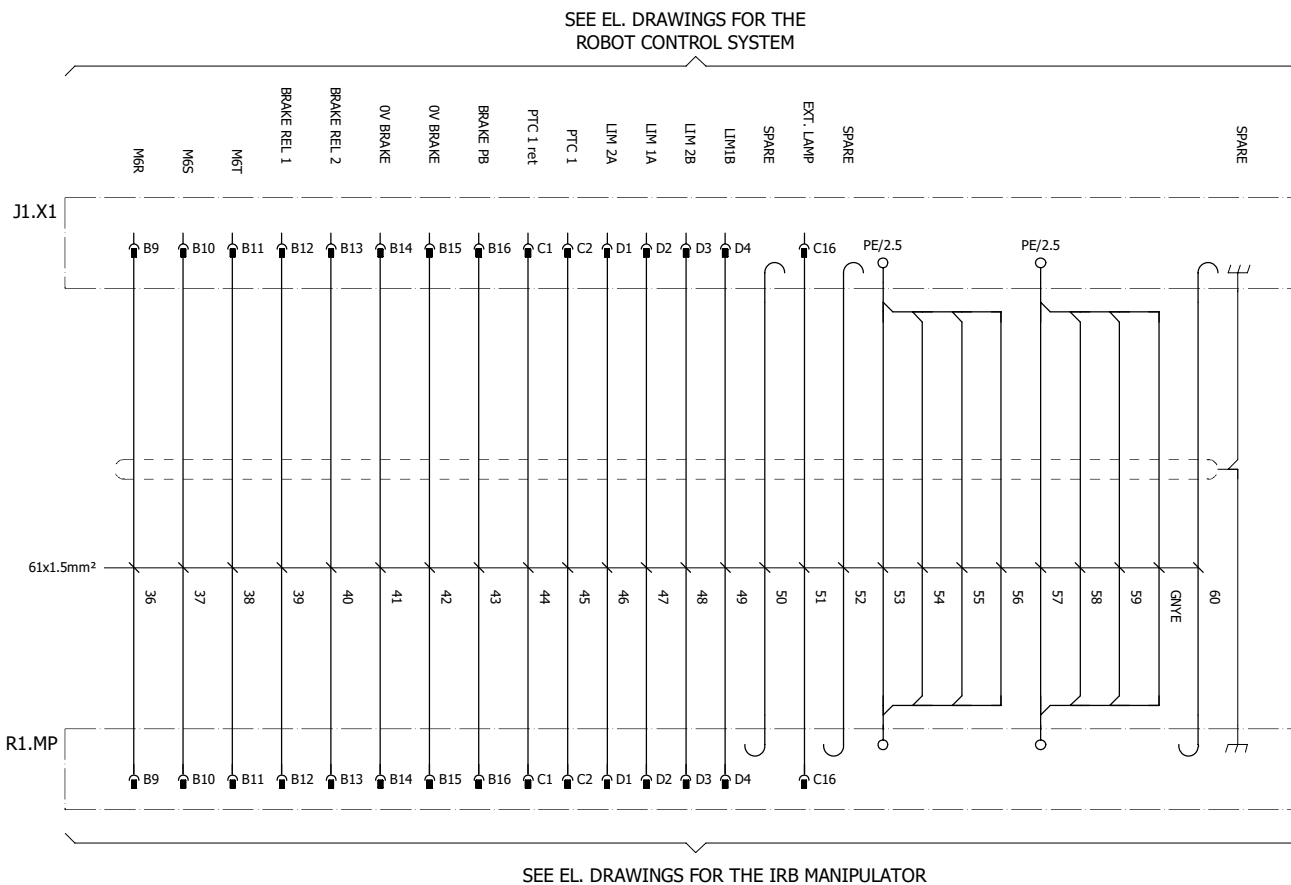

Responsible Department: RATY - RD	Design by: Yan Zhang
Prepare by, Date: CNYAZHA48, 20240915	Approve by, Date: CNFALEG, 20240920

IRT 710	
Replacement of	Replaced by



MOTOR CABLE, IRB4400

Status:
Approved
Document no.
3HKA00000191004

=	
+	
Rev.Ind	Page 25
	Total Page 33

We reserve all rights in this document and in the information contained therein. Reproduction, use or disclosure to third parties without express authority is strictly forbidden. Copyright ABB

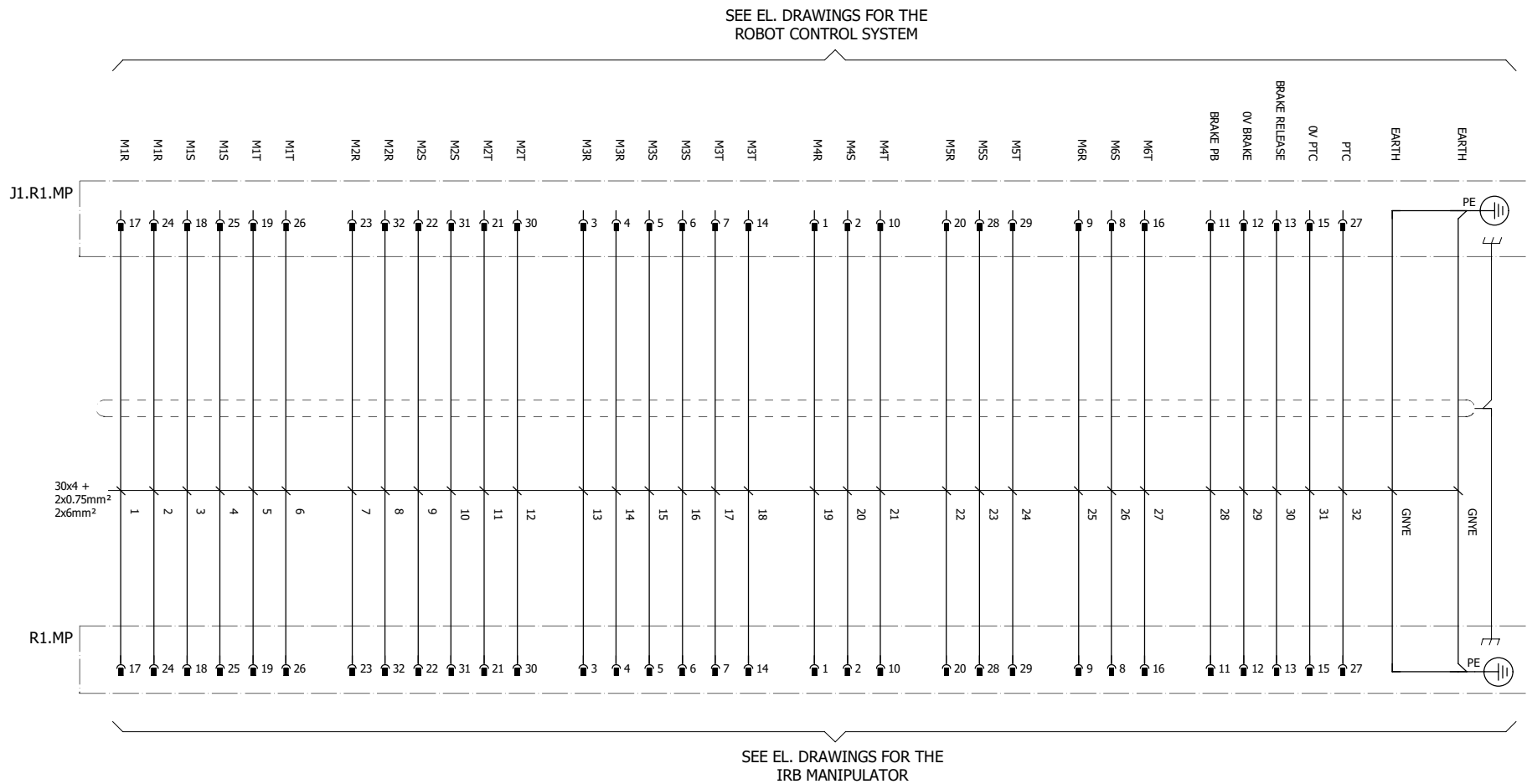

Responsible Department: RATY - RD Prepare by, Date: CNYAZHA48, 20240915	Design by: Yan Zhang Approve by, Date: CNFALEG, 20240920	IRT 710 Replacement of _____ Replaced by _____		MOTOR CABLE, IRB460/760/4400/4600/6xx0/7600	Status: Approved Document no. 3HKA00000191004	= +	Rev.Ind Page 26 Total Page 33
--	---	--	--	--	--	--------	-------------------------------------

SEE EL. DRAWINGS FOR THE
ROBOT CONTROL SYSTEM

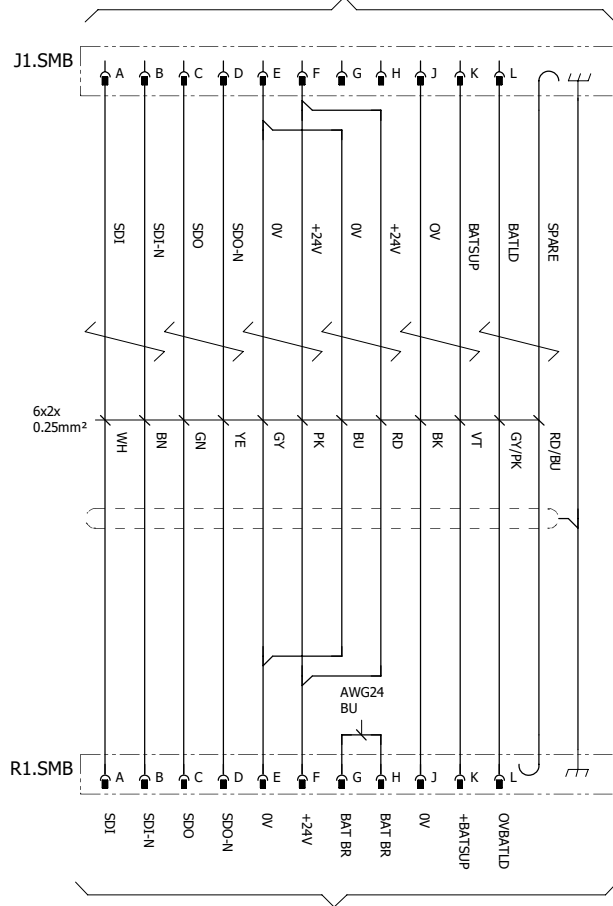

SEE EL.DWGS FOR THE
IRB MANIPULATOR

Responsible Department: RATY - RD	Design by: Yan Zhang
Prepare by, Date: CNYAZHA48, 20240915	Approve by, Date: CNFALEG, 20240920

IRT 710	Replacement of	Replaced by
---------	----------------	-------------



RESOLVER CABLE,
IRB460/760/4600/6xx0/7600

Status:
Approved
Document no.
3HKA00000191004

=	Rev.Ind	Page 27
+		Total Page 33

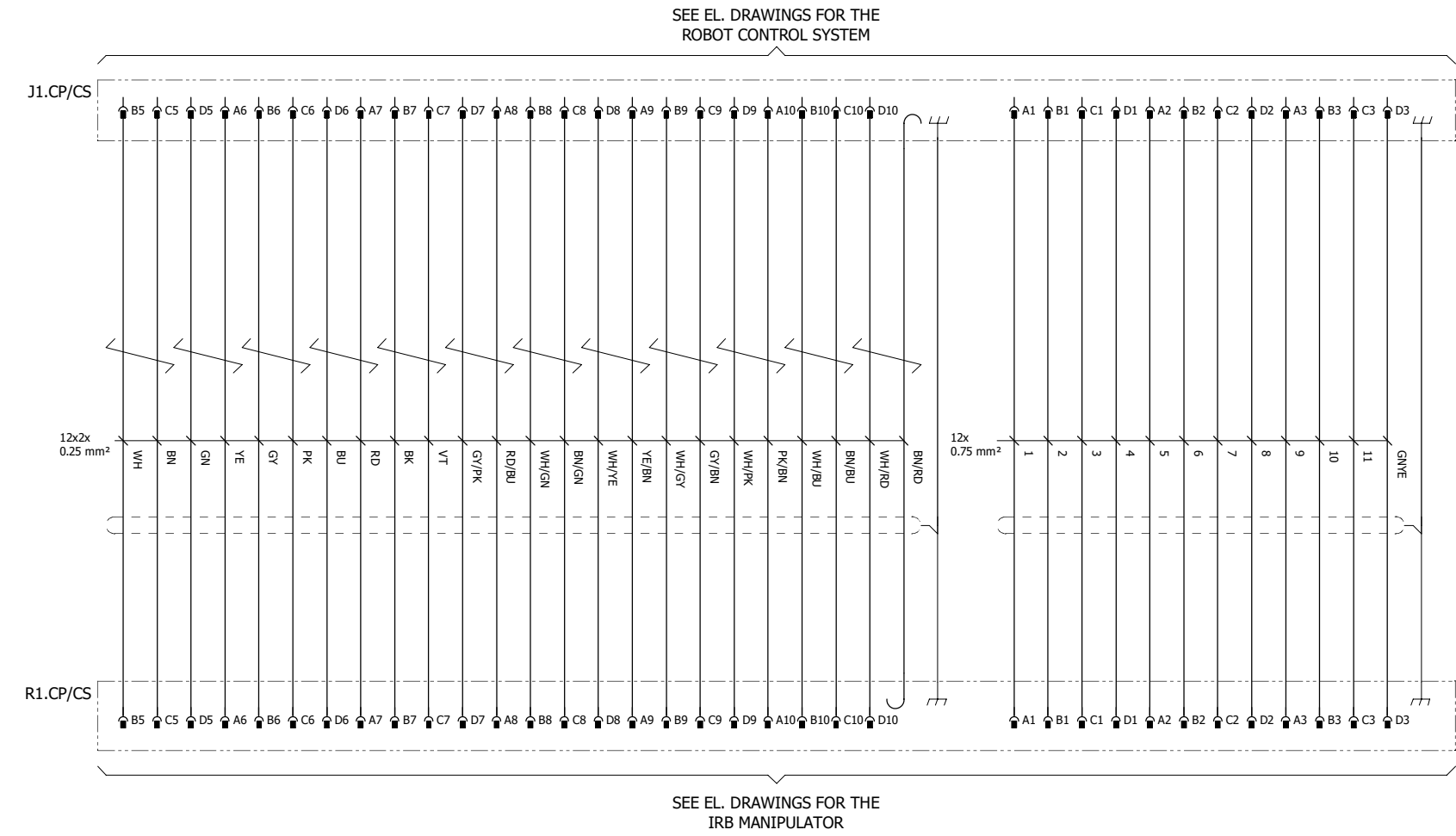

Responsible Department: RATY - RD	Design by: Yan Zhang
Prepare by, Date: CNYAZHA48, 20240915	Approve by, Date: CNFALEG, 20240920

IRT 710	
Replacement of	Replaced by



OPTION CUSTOMER POWER/SIGNAL,
IRB4400

Status:
Approved
Document no.
3HKA00000191004

Rev.Ind	Page 28
	Total Page 33

We reserve all rights in this document and in the information contained therein. Reproduction, use or disclosure to third parties without express authority is strictly forbidden. Copyright ABB

SEE EL. DRAWINGS FOR THE
ROBOT CONTROL SYSTEM

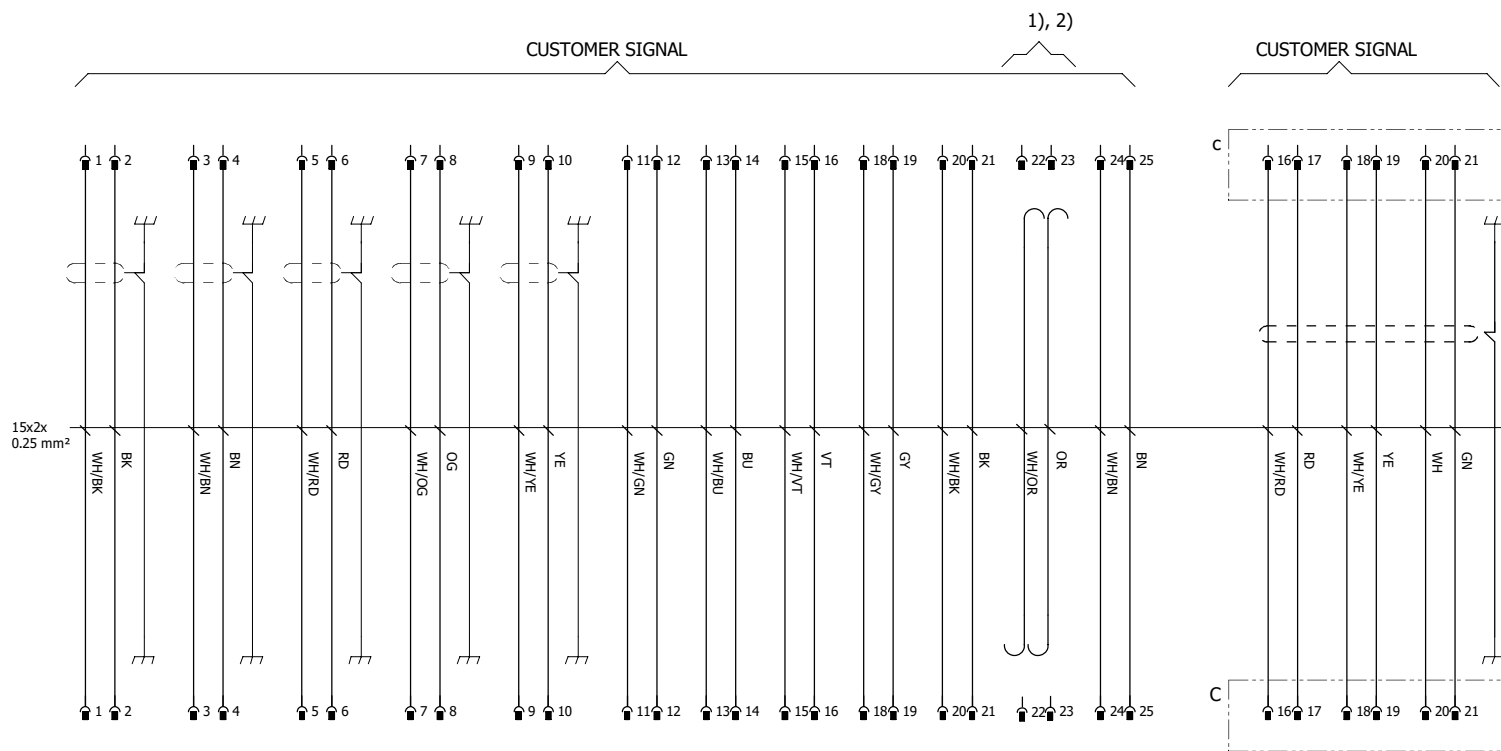

SEE EL. DRAWINGS FOR THE
IRB MANIPULATOR

Responsible Department: RATY - RD	Design by: Yan Zhang
Prepare by, Date: CNYAZHA48, 20240915	Approve by, Date: CNFALEG, 20240920

IRT 710	
Replacement of	Replaced by



OPTION CUSTOMER POWER/SIGNAL,
IRB460/760/4600/6xx0/7600

Status:
Approved
Document no.
3HKA00000191004

=	
+	
Rev.Ind	Page 29
	Total Page 33

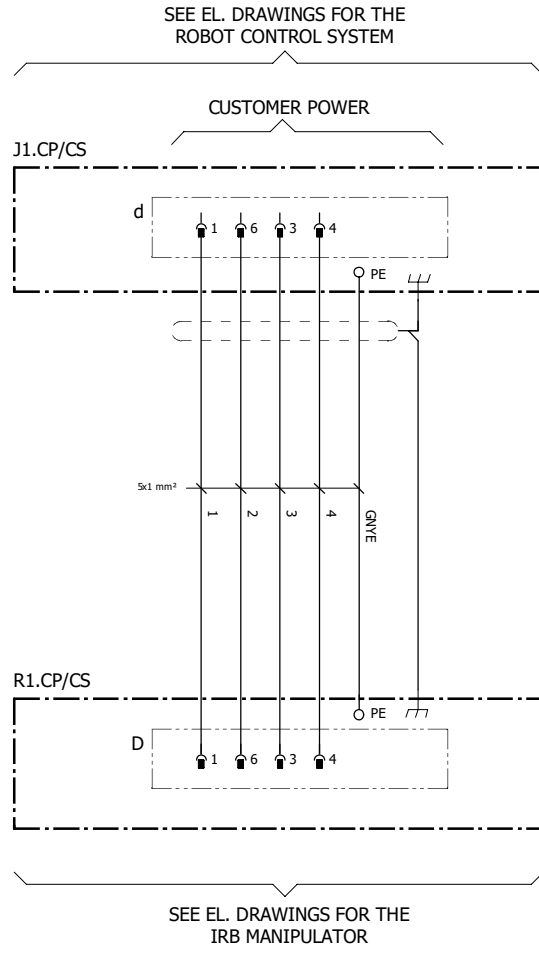

Responsible Department: RATY - RD	Design by: Yan Zhang
Prepare by, Date: CNYAZHA48, 20240915	Approve by, Date: CNFALEG, 20240920

IRT 710	
Replacement of	Replaced by



OPTION CUSTOMER POWER/SIGNAL
PARALLEL, IRB460/760/4600/6xx0/7600

Status: **Approved**
Document no.
3HKA00000191004

Rev.Ind	Page	30
+	Total Page	33

SEE EL. DRAWINGS FOR THE
ROBOT CONTROL SYSTEM

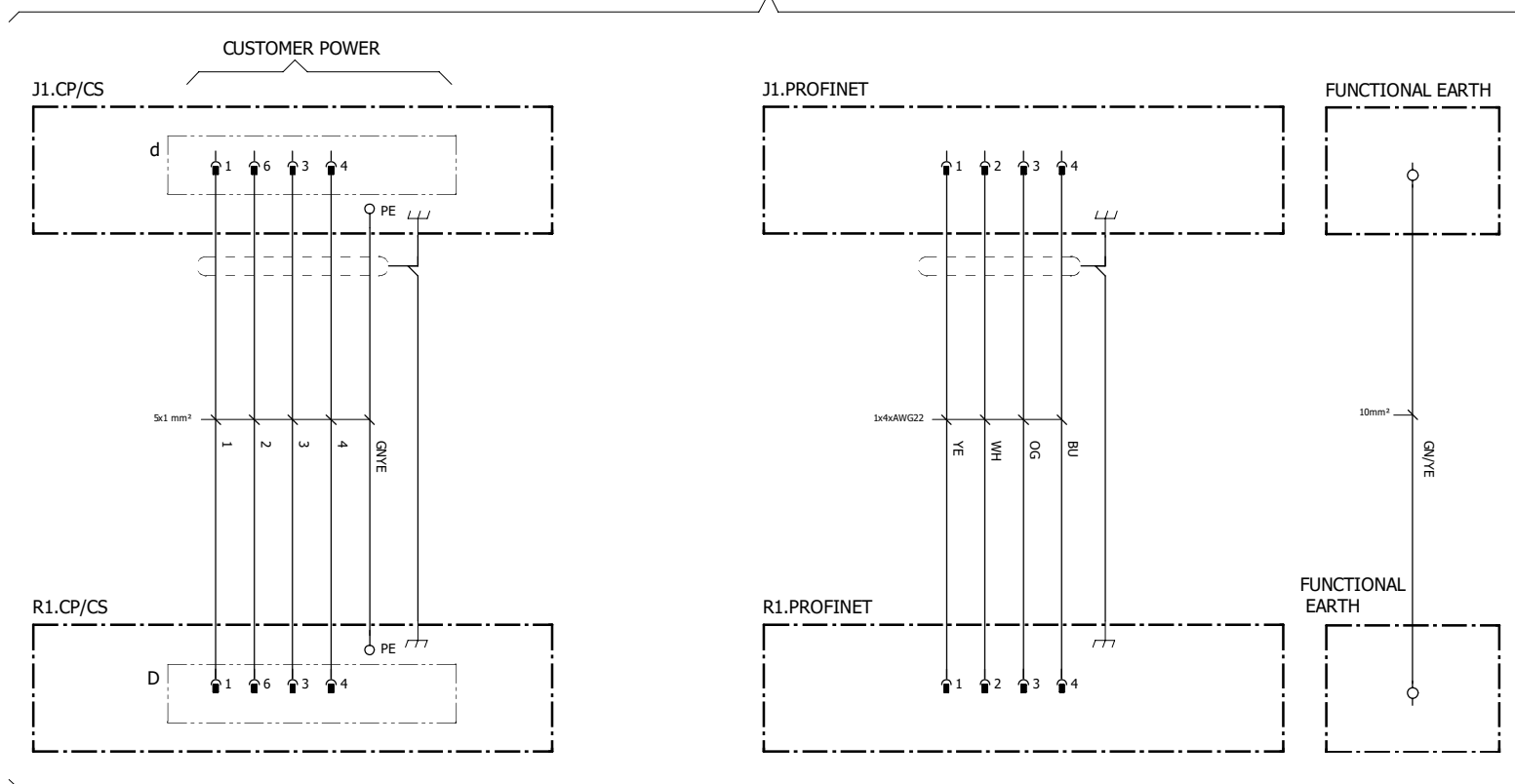

SEE EL. DRAWINGS FOR THE
IRB MANIPULATOR

Responsible Department: RATY - RD		Design by: Yan Zhang		IRT 710			OPTION CUSTOMER POWER/SIGNAL PROFINET, IRB460/760/4600/6xx0/7600	Status: Approved Document no. 3HKA00000191004	Rev.Ind Page 31 Total Page 33
Prepare by,Date:CNVAZHA48,20240915		Approve by,Date:CNFALEG,20240920		Replacement of					

We reserve all rights in this document and in the information contained therein. Reproduction, use or disclosure to third parties without express authority is strictly forbidden. Copyright ABB

SEE EL. DRAWINGS FOR THE
ROBOT CONTROL SYSTEM

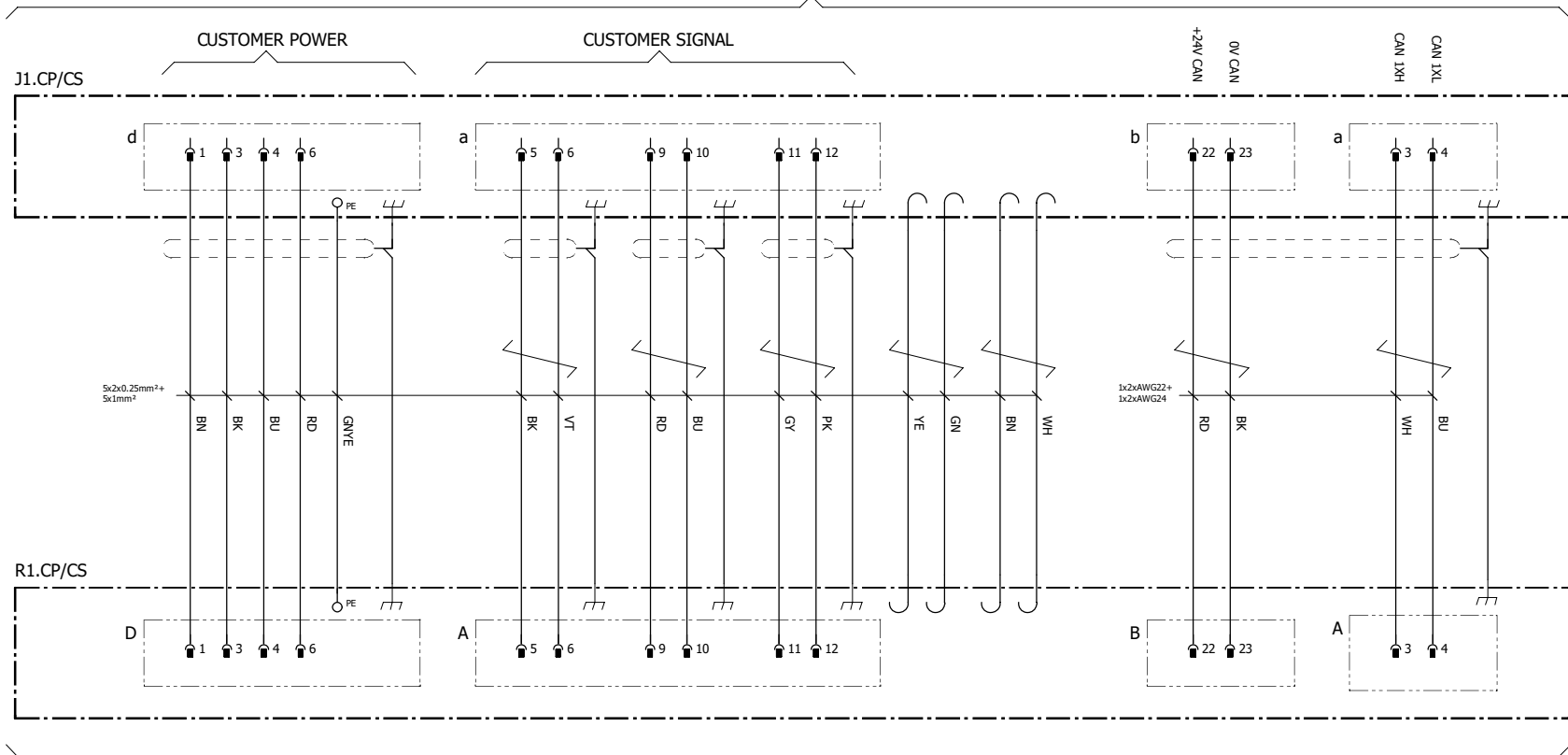

SEE EL. DRAWINGS FOR THE
IRB MANIPULATOR

Responsible Department: RATY - RD	Design by: Yan Zhang
Prepare by, Date: CNYAZHA48, 20240915	Approve by, Date: CNFALEG, 20240920

IRT 710	
Replacement of	Replaced by



OPTION CUSTOMER POWER/SIGNAL
DEVICENET,
IRB460/760/4600/6xx0/7600

Status:
Approved
Document no.
3HKA00000191004

Rev.Ind	Page 32
	Total Page 33

Revision comment

20220419 First version 001

20240915 Rev002

General update the cable connection point name according to harness drawing

Page 4-6 Clarify the harness connection and connection points.

Page 9 Change 3HAW050008614 to 3HAW050008613, change the SMB BOX circuit connection to 1axis.

Page 10 Correct the circuit connection of 3HAW050008614 and SMB Box.

Page 17 Delete the axis 2 and axis 3 circuit diagram of SMB BOX.

Page 24-27 Update the harness part number.

We reserve all rights in this document and in the information contained therein. Reproduction, use or disclosure to third parties without express authority is strictly forbidden. Copyright ABB

Responsible Department: RATY - RD Design by: Yan Zhang		IRT 710			Revision information	Status: Approved	=
Prepare by,Date:CNYAZHA48,20240915	Approve by,Date:CNFALEG,20240920	Replacement of	Replaced by			Document no. 3HKA00000191004	Rev.Ind